

EC20 Hardware Design

LTE Module Series

Rev. EC20_Hardware_Design_V1.1

Date: 2015-08-14



Our aim is to provide customers with timely and comprehensive service. For any assistance, please contact our company headquarters:

Quectel Wireless Solutions Co., Ltd.

Office 501, Building 13, No.99, Tianzhou Road, Shanghai, China, 200233

Tel: +86 21 5108 6236

Mail: info@quectel.com

Or our local office, for more information, please visit:

<http://www.quectel.com/support/salesupport.aspx>

For technical support, to report documentation errors, please visit:

<http://www.quectel.com/support/techsupport.aspx>

Or Email: Support@quectel.com

GENERAL NOTES

QUECTEL OFFERS THIS INFORMATION AS A SERVICE TO ITS CUSTOMERS. THE INFORMATION PROVIDED IS BASED UPON CUSTOMERS' REQUIREMENTS. QUECTEL MAKES EVERY EFFORT TO ENSURE THE QUALITY OF THE INFORMATION IT MAKES AVAILABLE. QUECTEL DOES NOT MAKE ANY WARRANTY AS TO THE INFORMATION CONTAINED HEREIN, AND DOES NOT ACCEPT ANY LIABILITY FOR ANY INJURY, LOSS OR DAMAGE OF ANY KIND INCURRED BY USE OF OR RELIANCE UPON THE INFORMATION. THE INFORMATION SUPPLIED HEREIN IS SUBJECT TO CHANGE WITHOUT PRIOR NOTICE.

COPYRIGHT

THIS INFORMATION CONTAINED HERE IS PROPRIETARY TECHNICAL INFORMATION OF QUECTEL CO., LTD. TRANSMITTABLE, REPRODUCTION, DISSEMINATION AND EDITING OF THIS DOCUMENT AS WELL AS UTILIZATION OF THIS CONTENTS ARE FORBIDDEN WITHOUT PERMISSION. OFFENDERS WILL BE HELD LIABLE FOR PAYMENT OF DAMAGES. ALL RIGHTS ARE RESERVED IN THE EVENT OF A PATENT GRANT OR REGISTRATION OF A UTILITY MODEL OR DESIGN.

Copyright © Quectel Wireless Solutions Co., Ltd. 2015. All rights reserved.

About the Document

History

Revision	Date	Author	Description
1.0	2015-02-13	Mountain ZHOU/ Mike ZHANG	Initial
1.1	2015-08-14	Mountain ZHOU	<ol style="list-style-type: none">1. Added UART interface pins2. Added FOTA upgrade mode3. Added EC20-CE info4. Updated module dimension information5. Updated EC20-C bands6. Updated functional diagram7. Updated power supply reference circuit8. Updated description of UART interface9. Updated current consumption10. Updated GNSS sensitivity

Contents

About the Document	2
Contents	3
Table Index	5
Figure Index	6
1 Introduction	7
1.1. Safety Information.....	8
2 Product Concept	9
2.1. General Description.....	9
2.2. Key Features.....	10
2.3. Functional Diagram.....	12
2.4. Evaluation Board.....	13
3 Application Interface	14
3.1. General Description.....	14
3.2. Pin Assignment.....	15
3.3. Pin Description.....	16
3.4. Operating Modes.....	21
3.5. Power Saving.....	22
3.5.1. Sleep Mode.....	22
3.5.1.1. UART Application.....	22
3.5.1.2. USB Application with USB Remote Wakeup Function.....	23
3.5.1.3. USB Application with USB Suspend/Resume and RI Function.....	23
3.5.1.4. USB Application without USB Suspend Function.....	24
3.5.2. Airplane Mode.....	25
3.6. Power Supply.....	25
3.6.1. Power Supply Pins.....	25
3.6.2. Decrease Voltage Drop.....	26
3.6.3. Reference Design for Power Supply.....	27
3.6.4. Monitor the Power Supply.....	27
3.7. Turn on and off Scenarios.....	28
3.7.1. Turn on Module Using the PWRKEY.....	28
3.7.2. Turn off Module.....	29
3.7.2.1. Turn off Module Using the PWRKEY Pin.....	30
3.7.2.2. Turn off Module Using AT Command.....	30
3.8. Reset the Module.....	30
3.9. USIM Card Interface.....	32
3.10. USB Interface.....	33
3.11. UART Interface.....	35
3.12. PCM and I2C Interface.....	37
3.13. ADC Function.....	39
3.14. Network Status Indication.....	40

3.15.	Operating Status Indication	41
3.16.	Behavior of the RI	42
4	GNSS Receiver	43
4.1.	General Description	43
4.2.	GNSS Performance	44
4.3.	Layout Guideline	45
5	Antenna Interface.....	46
5.1.	Main/Rx-diversity Antenna Interface.....	46
5.1.1.	Pin Definition	46
5.1.2.	Operating Frequency	46
5.1.3.	Reference Design	47
5.2.	GNSS Antenna Interface	48
5.3.	Antenna Installation	49
5.3.1.	Antenna Requirement	49
5.3.2.	Install the Antenna with RF Connector	50
6	Electrical, Reliability and Radio Characteristics	52
6.1.	Absolute Maximum Ratings	52
6.2.	Power Supply Ratings	53
6.3.	Operating Temperature.....	53
6.4.	Current Consumption	54
6.5.	RF Output Power	60
6.6.	RF Receiving Sensitivity.....	60
6.7.	Electrostatic Discharge	62
7	Mechanical Dimensions	63
7.1.	Mechanical Dimensions of the Module.....	63
7.2.	Footprint of Recommendation	65
7.3.	Top View of the Module	68
7.4.	Bottom View of the Module.....	68
8	Storage and Manufacturing	69
8.1.	Storage.....	69
8.2.	Manufacturing and Welding.....	69
8.3.	Packaging	70
9	Appendix A Reference.....	72
10	Appendix B GPRS Coding Scheme	76
11	Appendix C GPRS Multi-slot Class	77
12	Appendix D EDGE Modulation and Coding Scheme	78

Table Index

TABLE 1: EC20 SERIES FREQUENCY BANDS	9
TABLE 2: EC20 KEY FEATURES	10
TABLE 3: IO PARAMETERS DEFINITION.....	16
TABLE 4: PIN DESCRIPTION	16
TABLE 5: OVERVIEW OF OPERATING MODES.....	21
TABLE 6: VBAT AND GND PINS.....	26
TABLE 7: PWRKEY PIN DESCRIPTION	28
TABLE 8: RESET_N PIN DESCRIPTION	30
TABLE 9: PIN DEFINITION OF THE USIM INTERFACE	32
TABLE 10: USB PIN DESCRIPTION	33
TABLE 11: PIN DEFINITION OF THE UART INTERFACE.....	35
TABLE 12: PIN DEFINITION OF THE DEBUG UART INTERFACE.....	35
TABLE 13: LOGIC LEVELS OF DIGITAL I/O	36
TABLE 14: PIN DEFINITION OF PCM AND I2C INTERFACE.....	38
TABLE 15: PIN DEFINITION OF THE ADC	40
TABLE 16: CHARACTERISTIC OF THE ADC	40
TABLE 17: PIN DEFINITION OF NETWORK INDICATOR.....	40
TABLE 18: WORKING STATE OF THE NETWORK INDICATOR.....	41
TABLE 19: PIN DEFINITION OF STATUS	41
TABLE 20: BEHAVIOR OF THE RI	42
TABLE 21: GNSS PERFORMANCE	44
TABLE 22: PIN DEFINITION OF THE RF ANTENNA.....	46
TABLE 23: THE MODULE OPERATING FREQUENCIES.....	46
TABLE 24: PIN DEFINITION OF GNSS ANTENNA.....	48
TABLE 25: GNSS FREQUENCY.....	48
TABLE 26: ANTENNA REQUIREMENTS.....	49
TABLE 27: ABSOLUTE MAXIMUM RATINGS	52
TABLE 28: THE MODULE POWER SUPPLY RATINGS	53
TABLE 29: OPERATING TEMPERATURE.....	53
TABLE 30: EC20-A CURRENT CONSUMPTION	54
TABLE 31: EC20-C CURRENT CONSUMPTION	55
TABLE 32: EC20-E CURRENT CONSUMPTION	57
TABLE 33: CONDUCTED RF OUTPUT POWER	60
TABLE 34: EC20-A CONDUCTED RF RECEIVING SENSITIVITY	60
TABLE 35: EC20-C CONDUCTED RF RECEIVING SENSITIVITY.....	61
TABLE 36: EC20-E CONDUCTED RF RECEIVING SENSITIVITY.....	61
TABLE 37: ELECTROSTATICS DISCHARGE CHARACTERISTICS	62
TABLE 38: RELATED DOCUMENTS.....	72
TABLE 39: TERMS AND ABBREVIATIONS	72
TABLE 40: DESCRIPTION OF DIFFERENT CODING SCHEMES	76
TABLE 41: GPRS MULTI-SLOT CLASSES	77
TABLE 42: EDGE MODULATION AND CODING SCHEME	78

Figure Index

FIGURE 1: FUNCTIONAL DIAGRAM	13
FIGURE 2: PIN ASSIGNMENT (TOP VIEW).....	15
FIGURE 3: UART SLEEP APPLICATION	22
FIGURE 4: SLEEP APPLICATION WITH USB REMOTE WAKEUP	23
FIGURE 5: SLEEP APPLICATION WITH RI	24
FIGURE 6: SLEEP APPLICATION WITHOUT SUSPEND FUNCTION	24
FIGURE 7: POWER SUPPLY LIMITS DURING TRANSMIT BURST	26
FIGURE 8: STAR STRUCTURE OF THE POWER SUPPLY	27
FIGURE 9: REFERENCE CIRCUIT OF POWER SUPPLY	27
FIGURE 10: TURN ON THE MODULE USING DRIVING CIRCUIT	28
FIGURE 11: TURN ON THE MODULE USING KEYSTROKE.....	29
FIGURE 12: TIMING OF TURNING ON MODULE	29
FIGURE 13: TIMING OF TURNING OFF MODULE	30
FIGURE 14: REFERENCE CIRCUIT OF RESET_N BY USING DRIVING CIRCUIT	31
FIGURE 15: REFERENCE CIRCUIT OF RESET_N BY USING BUTTON	31
FIGURE 16: TIMING OF RESETTING MODULE	31
FIGURE 17: REFERENCE CIRCUIT OF THE 6 PIN USIM CARD.....	32
FIGURE 18: TEST POINTS FOR FIRMWARE UPGRADE	34
FIGURE 19: REFERENCE CIRCUIT WITH TRANSLATOR CHIP	36
FIGURE 20: REFERENCE CIRCUIT WITH TRANSISTOR CIRCUIT	37
FIGURE 21: PRIMARY MODE TIMING	38
FIGURE 22: AUXILIARY MODE TIMING	38
FIGURE 23: REFERENCE CIRCUIT OF PCM APPLICATION WITH AUDIO CODEC	39
FIGURE 24: REFERENCE CIRCUIT OF THE NETWORK INDICATOR.....	41
FIGURE 25: REFERENCE CIRCUIT OF THE STATUS	42
FIGURE 26: REFERENCE CIRCUIT OF ANTENNA INTERFACE	47
FIGURE 27: REFERENCE CIRCUIT OF GNSS ANTENNA.....	48
FIGURE 28: DIMENSIONS OF THE UF.L-R-SMT CONNECTOR (UNIT: MM)	50
FIGURE 29: MECHANICALS OF UF.L-LP CONNECTORS	50
FIGURE 30: SPACE FACTOR OF MATED CONNECTOR (UNIT: MM)	51
FIGURE 31: MODULE TOP AND SIDE DIMENSIONS.....	63
FIGURE 32: MODULE BOTTOM DIMENSIONS (BOTTOM VIEW)	64
FIGURE 33: BOTTOM PADS DIMENSIONS (BOTTOM VIEW)	64
FIGURE 34: RECOMMENDED FOOTPRINT (TOP VIEW)	65
FIGURE 35: RECOMMENDED STENCIL.....	66
FIGURE 36: RECOMMENDED FOOTPRINT WITH PINS 117~140	67
FIGURE 37: TOP VIEW OF THE MODULE	68
FIGURE 38: BOTTOM VIEW OF THE MODULE.....	68
FIGURE 39: LIQUIDS TEMPERATURE.....	70
FIGURE 40: CARRIER TAPE.....	71

1 Introduction

This document defines the EC20 module and describes its air interface and hardware interface which are connected with your application.

This document can help you quickly understand module interface specifications, electrical, mechanical details and related product information of EC20 module. Associated with application notes and user guide, you can use EC20 module to design and set up mobile applications easily.

Quectel
Confidential

1.1. Safety Information

The following safety precautions must be observed during all phases of the operation, such as usage, service or repair of any cellular terminal or mobile incorporating EC20 module. Manufacturers of the cellular terminal should send the following safety information to users and operating personnel and to incorporate these guidelines into all manuals supplied with the product. If not so, Quectel does not take on any liability for customer failure to comply with these precautions.



Full attention must be given to driving at all times in order to reduce the risk of an accident. Using a mobile while driving (even with a handsfree kit) cause distraction and can lead to an accident. You must comply with laws and regulations restricting the use of wireless devices while driving.



Switch off the cellular terminal or mobile before boarding an aircraft. Make sure it switched off. The operation of wireless appliances in an aircraft is forbidden to prevent interference with communication systems. Consult the airline staff about the use of wireless devices on boarding the aircraft, if your device offers a Airplane Mode which must be enabled prior to boarding an aircraft.



Switch off your wireless device when in hospitals or clinics or other health care facilities. These requests are desinged to prevent possible interference with sentitive medical equipment.



Cellular terminals or mobiles operate over radio frequency signal and cellular network and cannot be guaranteed to connect in all conditions, for example no mobile fee or an invalid SIM card. While you are in this condition and need emergent help, please remember using emergency call. In order to make or receive call, the cellular terminal or mobile must be switched on and in a service area with adequate cellular signal strength.



Your cellular terminal or mobile contains a transmitter and receiver. When it is ON , it receives and transmits radio frequency energy. RF interference can occur if it is used close to TV set, radio, computer or other electric equipment.



In locations with potentially explosive atmospheres, obey all posted signs to turn off wireless devices such as your phone or other cellular terminals. Areas with potentially expositive atmospheres including fuelling areas, below decks on boats, fuel or chemical transfer or storage facilities, areas where the air contains chemicals or particles such as grain, dust or metal powders.

2 Product Concept

2.1. General Description

EC20 is a series of LTE-FDD/LTE-TDD/WCDMA/TD-SCDMA/GSM wireless communication module with receive diversity, which provides data connectivity on FDD-LTE, TDD-LTE, DC-HSPA+, HSPA+, HSDPA, HSUPA, WCDMA, TD-SCDMA, CDMA, EDGE and GPRS networks. It can also provide GPS/GLONASS¹⁾ and voice functionality²⁾ for your specific application. EC20 contains three variants EC20-A, EC20-C, EC20-CE and EC20-E. You can choose the dedicated type based on the region or operator. The following table shows the product series of EC20.

Table 1: EC20 Series Frequency Bands

	EC20-A	EC20-C	EC20-CE	EC20-E
FDD-LTE (with Rx-diversity)	B2/B4/B5/B12/B17	B1/B3/B8	B1/B3	B1/B3/B5/B7/B8/B20
TDD-LTE (with Rx-diversity)	Not supported	B38/B39/B40/B41	B38/B39/B40/B41	Not supported
WCDMA (with Rx-diversity)	B2/B4/B5	B1/B8	B1	B1/B5/B8
TD-SCDMA (with Rx-diversity)	Not supported	B34/B39	B34/B39	Not supported
CDMA (with Rx-diversity)	Not supported	Not supported	BC0	Not supported
GSM	850/1900	900/1800	900/1800	850/900/1800/1900
GNSS	GPS+GLONASS	GPS+GLONASS	GPS+GLONASS	GPS+GLONASS

NOTES

1. GPS and GLONASS function is optional.
2. EC20 series (EC20-A/EC20-C/EC20-CE/EC20-E) includes **Data-only** and **Telematics** versions. **Data-only** version does not support voice function, **Telematics** version supports it.

With a tiny profile of 32.0mm × 29.0mm × 2.4mm, EC20 can meet almost all requirements for M2M application such as automotive, metering, tracking system, security solutions, routers, wireless POS, mobile computing devices, PDA phone and tablet PC, etc..

EC20 is an SMD type module, which can be embedded in application through its 140-pin pads including 76 LCC signal pads and 64 other pads.

2.2. Key Features

The following table describes the detailed features of EC20 module.

Table 2: EC20 Key Features

Feature	Details
Power Supply	Supply voltage: 3.3V~4.3V Typical supply voltage: 3.8V
Transmitting Power	Class 4 (33dBm±2dB) for GSM850 and EGSM900 Class 1 (30dBm±2dB) for DCS1800 and PCS1900 Class E2 (27dBm±3dB) for GSM850 and EGSM900 8-PSK Class E2 (26dBm±3dB) for DCS1800 and PCS1900 8-PSK Class 3 (24dBm+1/-3dB) for WCDMA bands Class 3 (24dBm+1/-3dB) for TD-SCDMA bands Class 3 (23dBm±2dB) for LTE FDD bands Class 3 (23dBm±2dB) for LTE TDD bands
LTE Features	Support 3GPP R9 CAT3 FDD and TDD Support 1.4 to 20MHz RF bandwidth Support 2 × 2 MIMO in DL direction FDD: Max 100Mbps (DL), 50Mbps (UL) TDD: Max 61Mbps (DL), 18Mbps (UL)
WCDMA Features	Support 3GPP R8 DC-HSPA+ Support 16-QAM, 64-QAM and QPSK modulation 3GPP R6 HSUPA: Max 5.76Mbps (UL) 3GPP R8 DC-HSPA+: Max 42Mbps (DL)
TD-SCDMA Features	Support 3GPP R8 1.28 TDD Max 4.2Mbps (DL), 2.2 Mbps (UL)
CDMA Features	Support 1x Advanced Max 14.7Mbps (UL), 5.4Mbps (DL)
GSM Features	R99: CSD: 9.6kbps, 14.4kbps GPRS: Support GPRS multi-slot class 12 (12 by default)

	<p>Coding scheme: CS-1, CS-2, CS-3 and CS-4 Maximum of four Rx time slots per frame EDGE: Support EDGE multi-slot class 12 (12 by default) Support GMSK and 8-PSK for different MCS (Modulation and Coding scheme) Downlink coding schemes: CS 1-4 and MCS 1-9 Uplink coding schemes: CS 1-4 and MCS 1-9</p>
Internet Protocol Features	<p>Support PPP protocols Support the protocols PAP (Password Authentication Protocol) and CHAP (Challenge Handshake Authentication Protocol) usually used for PPP connections</p>
SMS	<p>Text and PDU mode Point to point MO and MT SMS cell broadcast SMS storage: ME by default</p>
USIM Interface	<p>Support USIM/SIM card: 1.8V, 3.0V</p>
Audio Features ¹⁾	<p>Support one digital audio interface: PCM interface GSM: HR/FR/EFR/AMR/AMR-WB WCDMA: AMR/AMR-WB LTE: AMR/AMR-WB Echo cancellation and noise suppression</p>
PCM Interface ¹⁾	<p>Used for audio function with external codec Support 8-bit A-law ²⁾, μ-law ²⁾ and 16-bit linear data formats Support long frame sync and short frame sync Support master and slave mode, but must be the master in long frame sync</p>
USB Interface	<p>Compliant with USB 2.0 specification (slave only), the data transfer rate can reach up to 480Mbps Used for AT command communication, data transmission, GNSS NMEA output, software debug and firmware upgrade USB Driver: Windows XP, Windows Vista, Windows 7, Windows 8/8.1, Windows CE 5.0/6.0/7.0, Linux 2.6 or later, Android 2.3/4.0/4.2/4.4</p>
UART Interface	<p>Main UART: Used for AT command and data transmission Baud rate reach up to 921600bps, 115200bps by default Debug UART: Used for Linux console, log and GNSS NMEA output 115200bps baud rate</p>
Rx-diversity	<p>Support LTE/WCDMA/TD-SCDMA Rx-diversity</p>
GNSS Features	<p>gpsOne Gen8A of Qualcomm (GPS and GLONASS) Protocol: NMEA 0183</p>

AT Commands	Compliant with 3GPP TS 27.007, 27.005 and Quectel enhanced AT commands
Network Indication	Two pins including NET_MODE and NET_STATUS to indicate network connectivity status
Antenna Interface	Including main antenna (ANT_MAIN), Rx-diversity antenna (ANT_DIV) and GNSS antenna (ANT_GNSS)
Physical Characteristics	Size: 32.0±0.15 × 29.0±0.15 × 2.4±0.2mm Weight: approx. 4.9g
Temperature Range	Normal operation: -35°C ~ +75°C Restricted operation: -40°C ~ -35°C and +75°C ~ +85°C ³⁾ Storage temperature: -45°C ~ +90°C
Firmware Upgrade	USB interface and DFOTA
RoHS	All hardware components are fully compliant with EU RoHS directive

NOTES

- ¹⁾ Audio (PCM) function is only supported on **Telematics** version.
- ²⁾ This function is under development.
- ³⁾ When the module works within this restricted temperature range, RF performance might degrade. For example, the frequency error or the phase error would increase.

2.3. Functional Diagram

The following figure shows a block diagram of EC20 and illustrates the major functional parts.

- Power management
- Baseband
- DDR+NAND flash
- Radio frequency
- Peripheral interface

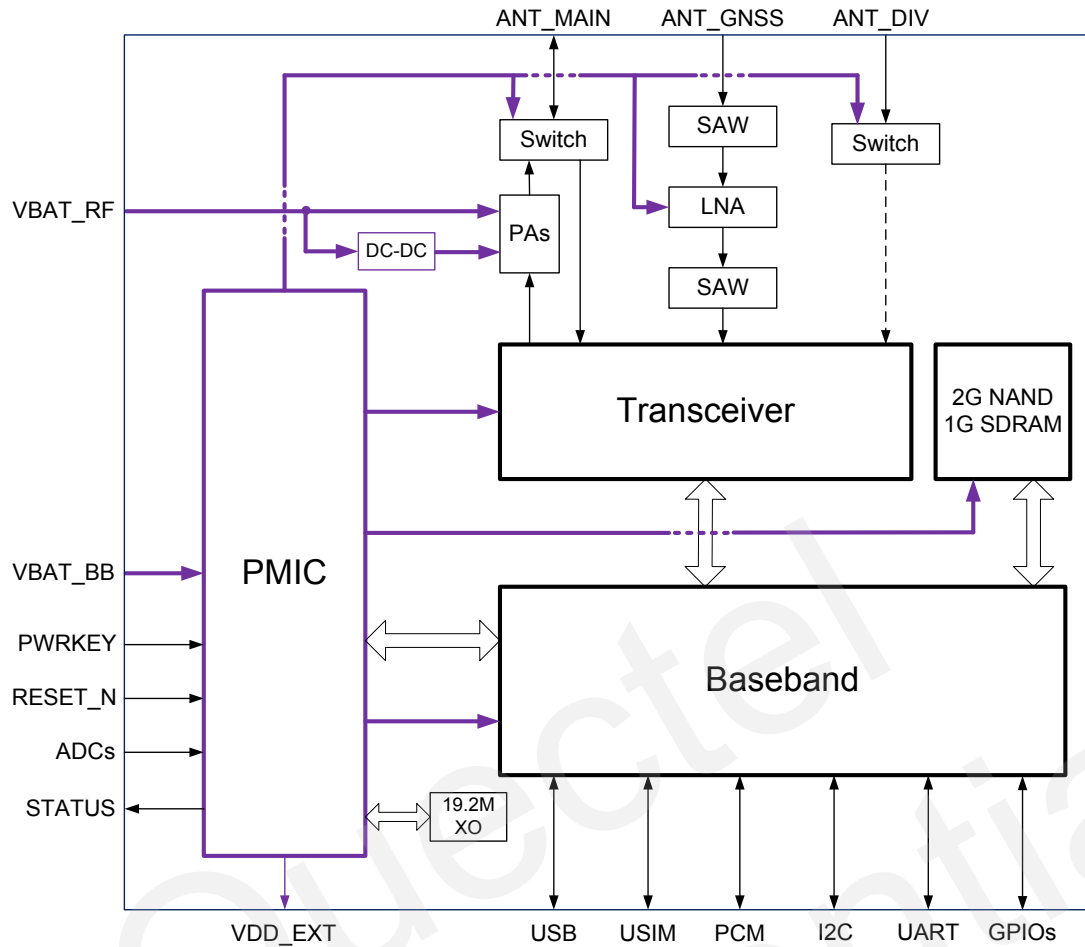

Figure 1: Functional Diagram

2.4. Evaluation Board

In order to help you to develop applications with EC20, Quectel supplies an evaluation board (EVB), USB data cable, earphone, antenna and other peripherals to control or test the module.

3 Application Interface

3.1. General Description

EC20 is equipped with a 76-pin 1.3mm pitch SMT pads plus 64-pin ground pads and reserved pads that connect to cellular application platform. Sub-interfaces included in these pads are described in detail in the following chapters:

- Power supply
- USIM interface
- USB interface
- UART interface
- PCM interface
- ADC interface
- Status indication

Quectel
Confidential

3.2. Pin Assignment

The following figure shows the pin assignment of the EC20 module.

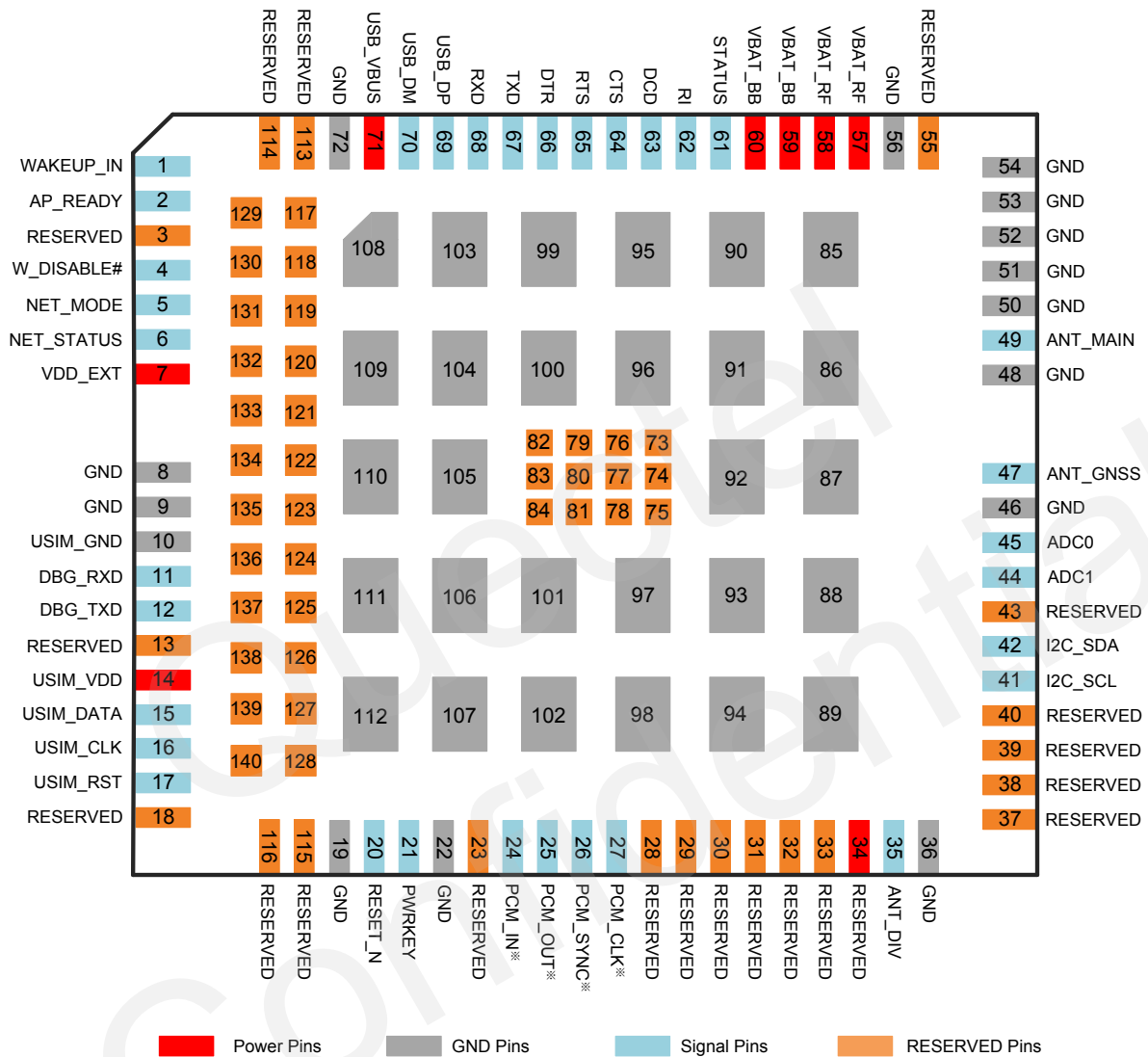

Figure 2: Pin Assignment (Top View)

NOTES

- Keep all RESERVED pins and unused pins unconnected.
- GND pads 85~112 should be connected to ground in the design, and RESERVED pads 73~84 and 117~140 should not be designed in schematic and PCB decal.
- * means these interface functions are only supported on **Telematics** version.

3.3. Pin Description

The following tables show the EC20's pin definition.

Table 3: IO Parameters Definition

Type	Description
IO	Bidirectional input/output
DI	Digital input
DO	Digital output
PI	Power input
PO	Power output
AI	Analog input
AO	Analog output
OD	Open drain

Table 4: Pin Description

Power Supply					
Pin Name	Pin No.	I/O	Description	DC Characteristics	Comment
VBAT_BB	59, 60	PI	Power supply for module baseband part.	Vmax=4.3V Vmin=3.3V Vnorm=3.8V	It must be able to provide sufficient current up to 0.8A.
VBAT_RF	57, 58	PI	Power supply for module RF part.	Vmax=4.3V Vmin=3.3V Vnorm=3.8V	It must be able to provide sufficient current in a transmitting burst which typically rises to 1.8A.
VDD_EXT	7	PO	Provide 1.8V for external circuit.	Vnorm=1.8V I _o max=50mA	Power supply for external GPIO's pull up circuits.
GND	8, 9, 19, 22, 36, 46, 48, 50~54,		Ground		

56, 72,
85~112

Turn On/Off

Pin Name	Pin No.	I/O	Description	DC Characteristics	Comment
PWRKEY	21	DI	Turn on/off the module	$V_{IHmax}=2.1V$ $V_{IHmin}=1.3V$ $V_{ILmax}=0.5V$	Pull-up to 1.8V internally.
RESET_N	20	DI	Reset the module	$V_{IHmax}=2.1V$ $V_{IHmin}=1.3V$ $V_{ILmax}=0.5V$	Pull-up to 1.8V internally. Active low.

Status Indication

Pin Name	Pin No.	I/O	Description	DC Characteristics	Comment
STATUS	61	OD	Indicate the module operating status.	The drive current should be less than 0.9mA.	Require external pull-up. If unused, keep it open.
NET_MODE	5	DO	Indicate the module network registration mode.	$V_{OHmin}=1.35V$ $V_{OLmax}=0.45V$	1.8V power domain. If unused, keep it open.
NET_STATUS	6	DO	Indicate the module network activity status.	$V_{OHmin}=1.35V$ $V_{OLmax}=0.45V$	1.8V power domain. If unused, keep it open.

USB Interface

Pin Name	Pin No.	I/O	Description	DC Characteristics	Comment
USB_VBUS	71	PI	USB detection	$V_{max}=5.25V$ $V_{min}=3.0V$ $V_{norm}=5.0V$	
USB_DP	69	IO	USB differential data bus	Compliant with USB 2.0 standard specification.	Require differential impedance of 90Ω.
USB_DM	70	IO	USB differential data bus	Compliant with USB 2.0 standard specification.	Require differential impedance of 90Ω.

USIM Interface

Pin Name	Pin No.	I/O	Description	DC Characteristics	Comment
USIM_GND	10		Specified ground for USIM card.		
USIM_VDD	14	PO	Power supply for	For 1.8V USIM:	Either 1.8V or 3V is

			USIM card.	V _{max} =1.9V V _{min} =1.7V	supported by the module automatically.
				For 3.0V USIM: V _{max} =3.05V V _{min} =2.7V I _{Omax} =50mA	
USIM_DATA	15	IO	Data signal of USIM card.	For 1.8V USIM: V _{ILmax} =0.6V V _{IHmin} =1.2V V _{OLmax} =0.45V V _{OHmin} =1.35V	
				For 3.0V USIM: V _{ILmax} =1.0V V _{IHmin} =1.95V V _{OLmax} =0.45V V _{OHmin} =2.55V	
USIM_CLK	16	DO	Clock signal of USIM card.	For 1.8V USIM: V _{OLmax} =0.45V V _{OHmin} =1.35V	
				For 3.0V USIM: V _{OLmax} =0.45V V _{OHmin} =2.55V	
USIM_RST	17	DO	Reset signal of USIM card.	For 1.8V USIM: V _{OLmax} =0.45V V _{OHmin} =1.35V	
				For 3.0V USIM: V _{OLmax} =0.45V V _{OHmin} =2.55V	

UART Interface

Pin Name	Pin No.	I/O	Description	DC Characteristics	Comment
RI	62	DO	Ring indicator	V _{OLmax} =0.45V V _{OHmin} =1.35V	1.8V power domain. If unused, keep it open.
DCD	63	DO	Data carrier detection.	V _{OLmax} =0.45V V _{OHmin} =1.35V	1.8V power domain. If unused, keep it open.
CTS	64	DO	Clear to send	V _{OLmax} =0.45V V _{OHmin} =1.35V	1.8V power domain. If unused, keep it

					open.
RTS	65	DI	Request to send	$V_{ILmin}=-0.3V$ $V_{ILmax}=0.6V$ $V_{IHmin}=1.2V$ $V_{IHmax}=2.0V$	1.8V power domain. If unused, keep it open.
DTR	66	DI	Data terminal ready, sleep mode control.	$V_{ILmin}=-0.3V$ $V_{ILmax}=0.6V$ $V_{IHmin}=1.2V$ $V_{IHmax}=2.0V$	1.8V power domain. Pull-up by default. Low level wakes up the module. If unused, keep it open.
TXD	67	DO	Transmit data	$V_{OLmax}=0.45V$ $V_{OHmin}=1.35V$	1.8V power domain. If unused, keep it open.
RXD	68	DI	Receive data	$V_{ILmin}=-0.3V$ $V_{ILmax}=0.6V$ $V_{IHmin}=1.2V$ $V_{IHmax}=2.0V$	1.8V power domain. If unused, keep it open.

Debug UART Interface

Pin Name	Pin No.	I/O	Description	DC Characteristics	Comment
DBG_TXD	12	DO	Transmit data	$V_{OLmax}=0.45V$ $V_{OHmin}=1.35V$	1.8V power domain. If unused, keep it open.
DBG_RXD	11	DI	Receive data	$V_{ILmin}=-0.3V$ $V_{ILmax}=0.6V$ $V_{IHmin}=1.2V$ $V_{IHmax}=2.0V$	1.8V power domain. If unused, keep it open.

ADC Interface

Pin Name	Pin No.	I/O	Description	DC Characteristics	Comment
ADC0	45	AI	General purpose analog to digital converter.	Voltage range: 0.3V to VBAT_BB	If unused, keep it open.
ADC1	44	AI	General purpose analog to digital converter.	Voltage range: 0.3V to VBAT_BB	If unused, keep it open.

PCM Interface

Pin Name	Pin No.	I/O	Description	DC Characteristics	Comment
----------	---------	-----	-------------	--------------------	---------

PCM_IN	24	DI	PCM data input	$V_{ILmin}=-0.3V$ $V_{ILmax}=0.6V$ $V_{IHmin}=1.2V$ $V_{IHmax}=2.0V$	1.8V power domain. If unused, keep it open.
PCM_OUT	25	DO	PCM data output	$V_{OLmax}=0.45V$ $V_{OHmin}=1.35V$	1.8V power domain. If unused, keep it open.
PCM_SYNC	26	IO	PCM data frame sync signal.	$V_{OLmax}=0.45V$ $V_{OHmin}=1.35V$ $V_{ILmin}=-0.3V$ $V_{ILmax}=0.6V$ $V_{IHmin}=1.2V$ $V_{IHmax}=2.0V$	1.8V power domain. In master mode, it is an output signal. In slave mode, it is an input signal. If unused, keep it open.
PCM_CLK	27	IO	PCM data bit clock	$V_{OLmax}=0.45V$ $V_{OHmin}=1.35V$ $V_{ILmin}=-0.3V$ $V_{ILmax}=0.6V$ $V_{IHmin}=1.2V$ $V_{IHmax}=2.0V$	1.8V power domain. In master mode, it's an output signal. In slave mode, it is an input signal. If unused, keep it open.

I2C Interface

Pin Name	Pin No.	I/O	Description	DC Characteristics	Comment
I2C_SCL	41	OD	I2C serial clock		External pull-up resistor is required. 1.8V only. If unused, keep it open.
I2C_SDA	42	OD	I2C serial data		External pull-up resistor is required. 1.8V only. If unused, keep it open.

RF Interface

Pin Name	Pin No.	I/O	Description	DC Characteristics	Comment
ANT_DIV	35	AI	Diversity antenna	50Ω impedance	If unused, keep it open.
ANT_MAIN	49	IO	Main antenna	50Ω impedance	
ANT_GNSS	47	AI	GNSS antenna	50Ω impedance	If unused, keep it open.

GPIO Pins

Pin Name	Pin No.	I/O	Description	DC Characteristics	Comment
----------	---------	-----	-------------	--------------------	---------

WAKEUP_IN	1	DI	Sleep mode control	$V_{ILmin}=-0.3V$ $V_{ILmax}=0.6V$ $V_{IHmin}=1.2V$ $V_{IHmax}=2.0V$	1.8V power domain. Pull-up by default. Low level wakes up the module. If unused, keep it open.
W_DISABLE#	4	DI	Airplane mode control.	$V_{ILmin}=-0.3V$ $V_{ILmax}=0.6V$ $V_{IHmin}=1.2V$ $V_{IHmax}=2.0V$	1.8V power domain. Pull-up by default. In low voltage level, module can enter into airplane mode. If unused, keep it open.
AP_READY	2	DI	Application processor sleep state detection.	$V_{ILmin}=-0.3V$ $V_{ILmax}=0.6V$ $V_{IHmin}=1.2V$ $V_{IHmax}=2.0V$	1.8V power domain. If unused, keep it open.

RESERVED Pins

Pin Name	Pin No.	I/O	Description	DC Characteristics	Comment
RESERVED	3, 13, 18, 23, 28~34, 37~40, 43, 55, 73~84, 113~140		Reserved		Keep these pins unconnected.

3.4. Operating Modes

The table below briefly summarizes the various operating modes referred in the following chapters.

Table 5: Overview of Operating Modes

Mode	Details
Normal Operation	Idle Software is active. The module has registered to the network, and the module is ready to send and receive data.
	Talk/Data Network connection is ongoing. In this mode, the power consumption is decided by network setting and data transfer rate.
Minimum Functionality Mode	AT+CFUN command can set the module entering into a minimum functionality mode without removing the power supply. In this case, both RF function and USIM card will be invalid.
Airplane Mode	AT+CFUN command and W_DISABLE# pin can set the module entering into airplane mode. In this case, RF function will be invalid.

Sleep Mode	In this mode, the current consumption of the module will be reduced to the minimal level. During this mode, the module can still receive paging message, SMS, voice call and TCP/UDP data from the network normally.
Power Down Mode	In this mode, the power management unit shuts down the power supply. Software is not active. The serial interface is not accessible. Operating voltage (connected to VBAT_RF and VBAT_BB) remains applied.

3.5. Power Saving

3.5.1. Sleep Mode

EC20 is able to reduce its current consumption to a minimum value during the sleep mode. The following section describes EC20's power saving procedure.

3.5.1.1. UART Application

If host communicates with module via UART interface, the following preconditions can let the module enter into the sleep mode.

- Execute AT command **AT+QSCLK=1** to enable the sleep mode.
- Drive DTR to high level.

The following figure shows the connection between the module and host.

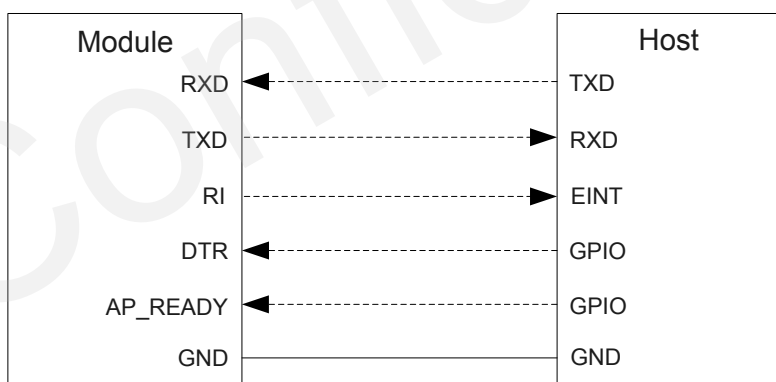

Figure 3: UART Sleep Application

- Driving host DTR to low level will wake up the module.
- When EC20 has URC to report, RI signal will wake up the host. Refer to **Chapter 3.16** for details about RI behavior.
- AP_READY will detect the sleep state of host (can be configured to high level or low level detection).

3.5.1.2. USB Application with USB Remote Wakeup Function

If host supports USB suspend/resume and remote wakeup function, the following part will show the sleep application.

There are three preconditions to let the module enter into the sleep mode.

- Execute AT command **AT+QSCLK=1** to enable the sleep mode.
- Ensure the DTR is held in high level or keep it open.
- The host's USB bus which is connected with the module USB interface enters into suspended state.

The following figure shows the connection between the module and host.

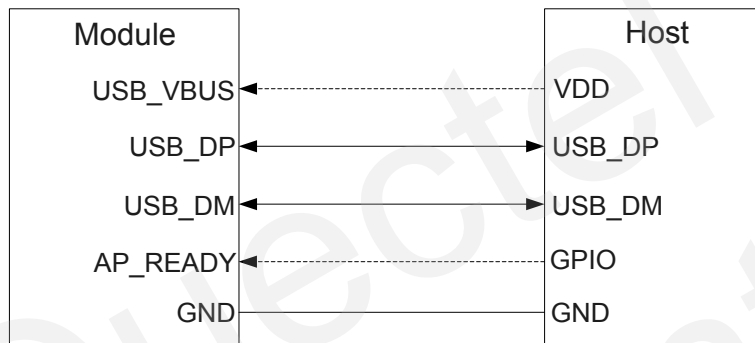

Figure 4: Sleep Application with USB Remote Wakeup

- Sending data to EC20 through USB will wake up the module.
- When EC20 has URC to report, module will send remote wake-up signals on USB BUS to wake up the host.

3.5.1.3. USB Application with USB Suspend/Resume and RI Function

If host supports USB suspend/resume, but does not support remote wake-up function, the RI signal is needed to wake up the host. The following part will show the sleep application.

There are three preconditions to let the module enter into the sleep mode.

- Execute AT command **AT+QSCLK=1** to enable the sleep mode.
- Ensure the DTR is held in high level or keep it open.
- The host's USB bus which is connected with the module USB interface enters into suspended state.

The following figure shows the connection between the module and host.

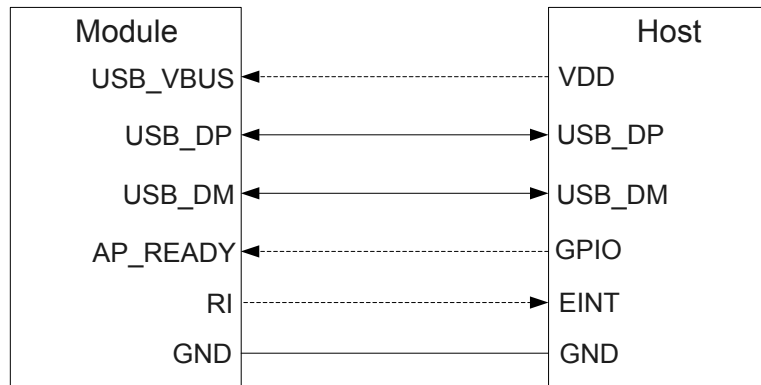

Figure 5: Sleep Application with RI

- Sending data to EC20 through USB will wake up the module.
- When EC20 has URC to report, RI signal will wake up the host.

3.5.1.4. USB Application without USB Suspend Function

If host does not support USB suspend function, you should disconnect USB_VBUS with additional control circuit to let the module enter into sleep mode.

- Execute AT command **AT+QSCLK=1** to enable the sleep mode.
- Ensure the DTR is held in high level or keep it open.
- Disconnect USB_VBUS.

The following figure shows the connection between the module and host.

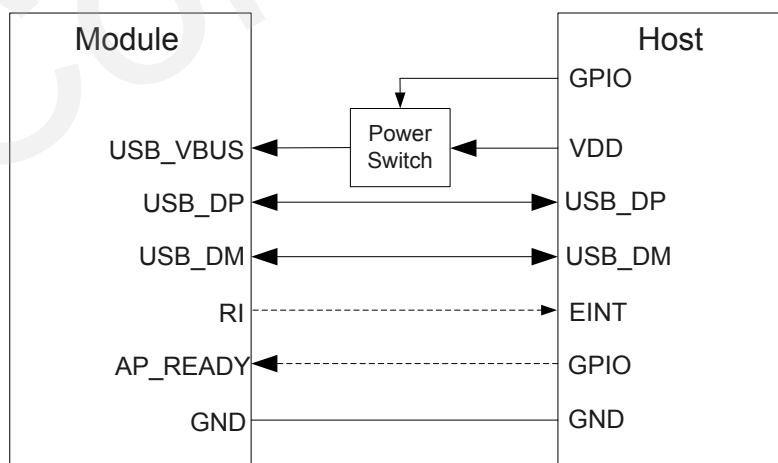

Figure 6: Sleep Application without Suspend Function

Opening power switch to supply power to USB_VBUS will wake up the module.

NOTE

You should pay attention to the level match shown in dotted line between module and host. Refer to **document [1]** for more details about EC20 power management application.

3.5.2. Airplane Mode

When module enters into the airplane mode, the RF function does not work, and all AT commands correlative with RF function will not be accessible. This mode can be set with the following ways.

Hardware:

The W_DISABLE# pin is pulled up by default, driving it to low level will let the module enter into airplane mode.

Software:

Command **AT+CFUN** provides the choice of the functionality level <fun>=0, 1, 4.

- **AT+CFUN=0**: Minimum functionality mode, both USIM and RF function are disabled.
- **AT+CFUN=1**: Full functionality mode (by default).
- **AT+CFUN=4**: Airplane mode. RF function is disabled.

NOTES

1. The W_DISABLE# control function is disabled in firmware by default. It can be enabled by AT command **AT+QCFG="airplanecontrol"**. Refer to **document [2]**.
2. The execution of **AT+CFUN** command will not affect GNSS function.

3.6. Power Supply

3.6.1. Power Supply Pins

EC20 provides four VBAT pins dedicated to connect with the external power supply. There are two separate voltage domains for VBAT.

- VBAT_RF with two pins for module RF part.
- VBAT_BB with two pins for module baseband part.

The following table shows the VBAT pins and ground pins.

Table 6: VBAT and GND Pins

Pin Name	Pin No.	Description	Min.	Typ.	Max.	Unit
VBAT_RF	57, 58	Power supply for module RF part.	3.3	3.8	4.3	V
VBAT_BB	59, 60	Power supply for module baseband part.	3.3	3.8	4.3	V
GND	8, 9, 19, 22, 36, 46, 48, 50~54, 56, 72, 85~112	Ground	-	0	-	V

3.6.2. Decrease Voltage Drop

The power supply range of the module is 3.3V ~ 4.3V. Make sure the input voltage will never drop below 3.3V. The following figure shows the voltage drop during transmitting burst in 2G network, the voltage drop will be less in 3G and 4G network.

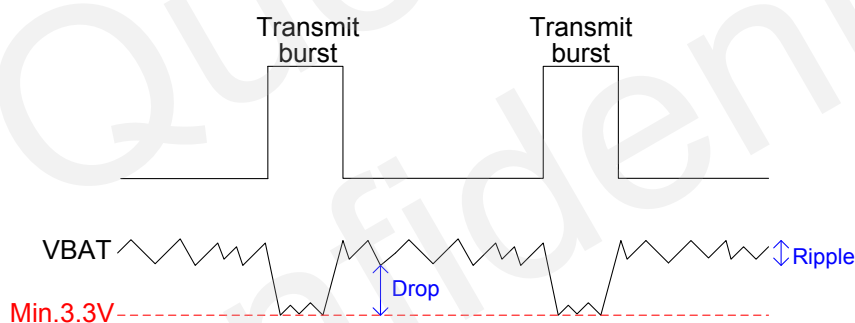

Figure 7: Power Supply Limits during Transmit Burst

To decrease voltage drop, a bypass capacitor of about 100μF with low ESR should be used. Multi-layer ceramic chip (MLCC) capacitor can provide the best combination of low ESR. The main power supply from an external application has to be a single voltage source and expanded to two sub paths with star structure. The width of VBAT_BB trace should be no less than 1mm, and the width of VBAT_RF trace should be no less than 2mm, and the principle of the VBAT trace is the longer, the wider.

Three ceramic capacitors (100nF, 33pF, 10pF) are recommended to be applied to the VBAT pins. The capacitors should be placed close to the VBAT pins. In addition, in order to get a stable power source, it is suggested that you should use a zener diode of which reverse zener voltage is 5.1V and dissipation power is more than 0.5W. The following figure shows star structure of the power supply.

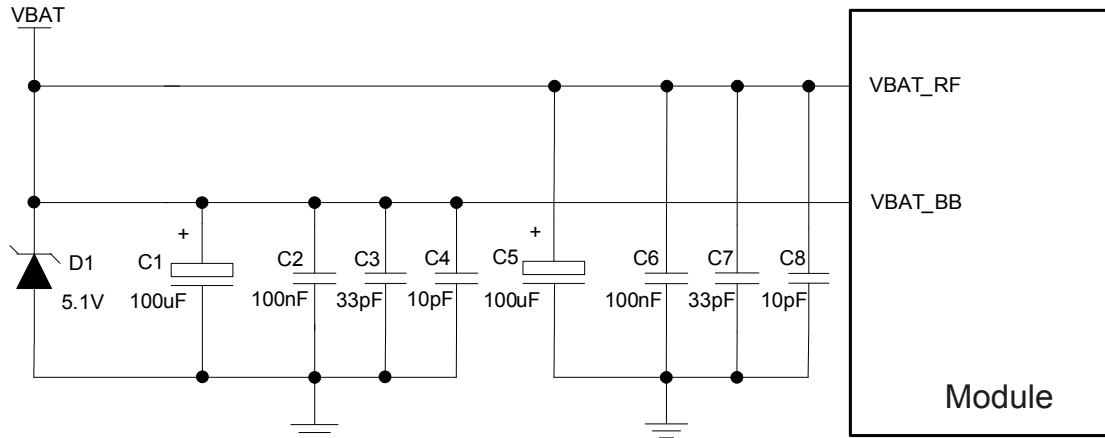

Figure 8: Star Structure of the Power Supply

3.6.3. Reference Design for Power Supply

The power design for the module is very important, since the performance of power supply for the module largely depends on the power source. The power supply is capable of providing the sufficient current up to 2A at least. If the voltage drop between the input and output is not too high, it is suggested that you should use a LDO to supply power for module. If there is a big voltage difference between the input source and the desired output (VBAT), a buck converter is preferred to be used as a power supply.

The following figure shows a reference design for +5V input power source. The designed output for the power supply is about 3.8V and the maximum load current is 3A.

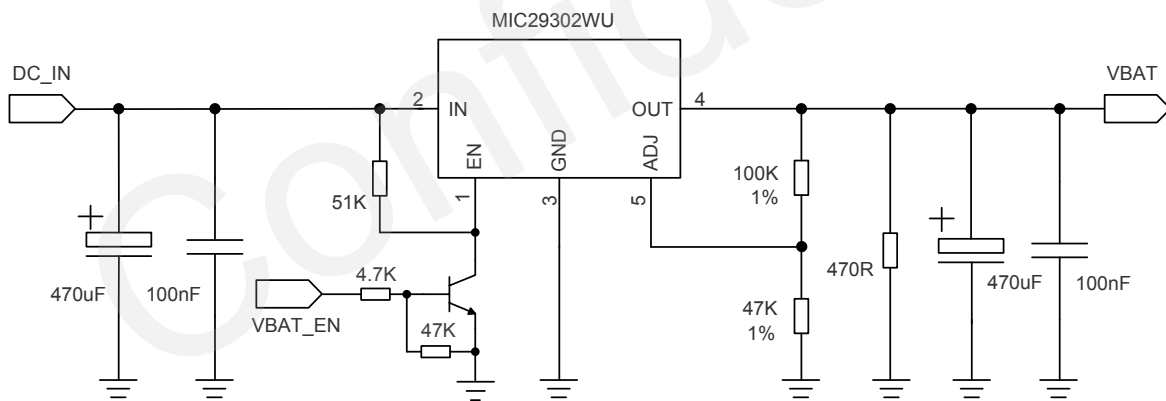

Figure 9: Reference Circuit of Power Supply

3.6.4. Monitor the Power Supply

You can use the **AT+CBC** command to monitor the VBAT_BB voltage value. For more details, please refer to [document \[2\]](#).

3.7. Turn on and off Scenarios

3.7.1. Turn on Module Using the PWRKEY

The following table shows the pin definition of PWRKEY.

Table 7: PWRKEY Pin Description

Pin Name	Pin No.	Description	DC Characteristics	Comment
PWRKEY	21	Turn on/off the module	$V_{IHmax}=2.1V$ $V_{IHmin}=1.3V$ $V_{ILmax}=0.5V$	Pull-up to 1.8V internally

When EC20 is in power down mode, it can be turned on to normal mode by driving the PWRKEY pin to a low level for at least 100ms. It is recommended to use an open drain/collector driver to control the PWRKEY. After STATUS pin (require external pull-up) outputting a low level, PWRKEY pin can be released. A simple reference circuit is illustrated in the following figure.

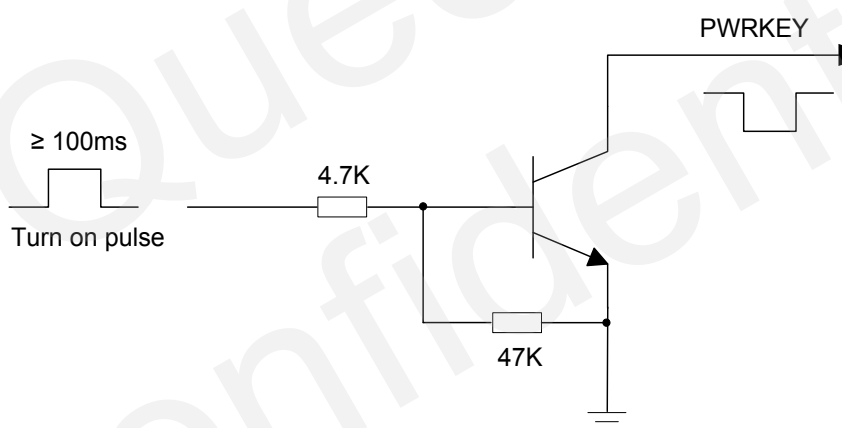

Figure 10: Turn on the Module Using Driving Circuit

The other way to control the PWRKEY is using a button directly. A TVS component is indispensable to be placed nearby the button for ESD protection. When pressing the key, electrostatic strike may generate from finger. A reference circuit is shown in the following figure.

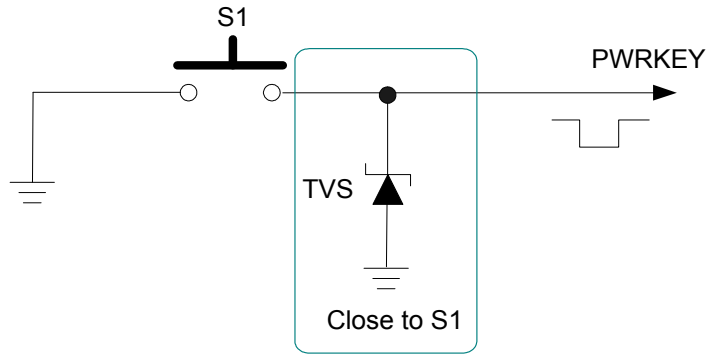

Figure 11: Turn on the Module Using Keystroke

The turn on scenarios is illustrated as the following figure.

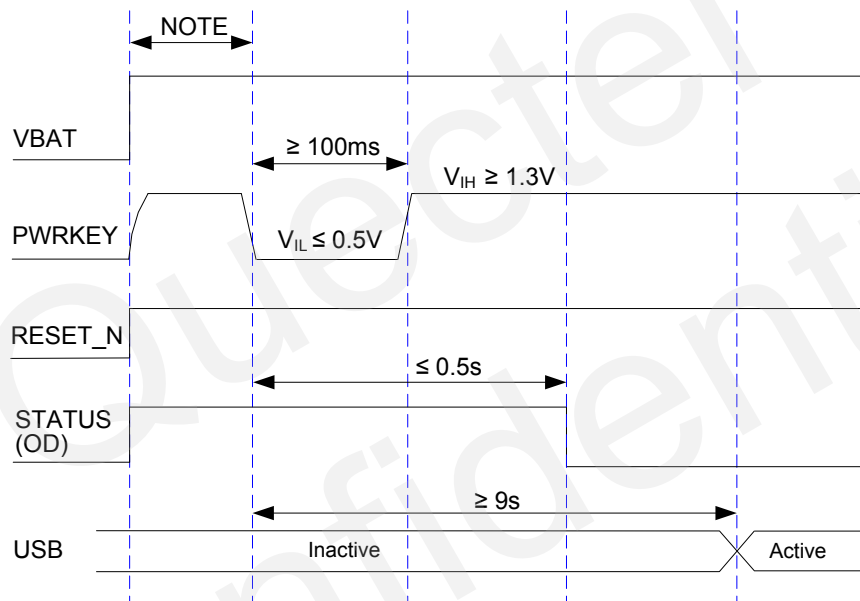

Figure 12: Timing of Turning on Module

NOTE

Make sure that VBAT is stable before pulling down PWRKEY pin. The time between them is no less than 30ms.

3.7.2. Turn off Module

The following procedures can be used to turn off the module:

- Normal power down procedure: Turn off the module using the PWRKEY pin.
- Normal power down procedure: Turn off the module using command **AT+QPOWD**.

3.7.2.1. Turn off Module Using the PWRKEY Pin

Driving the PWRKEY to a low level voltage for at least 0.6s, the module will execute power-down procedure after PWRKEY is released. The power-down scenario is illustrated as the following figure.

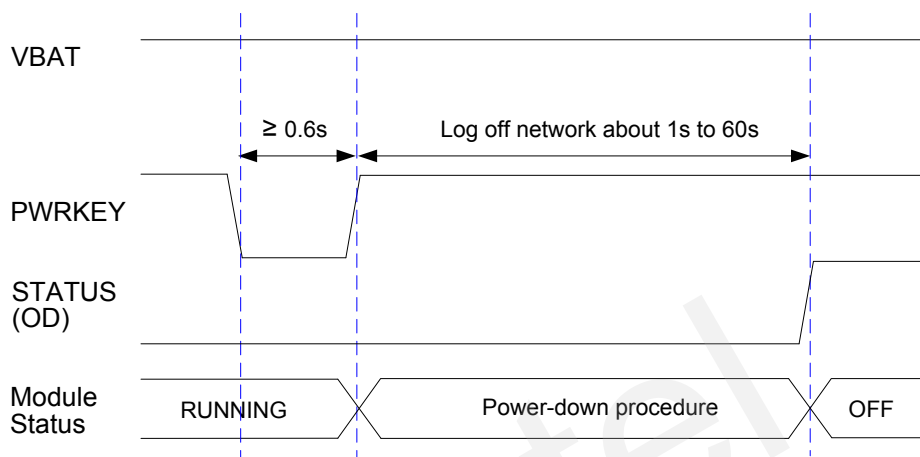

Figure 13: Timing of Turning off Module

3.7.2.2. Turn off Module Using AT Command

It is also a safe way to use AT command **AT+QPOWD** to turn off the module, which is similar to turning off the module via PWRKEY Pin.

Please refer to **document [2]** for details about the AT command of **AT+QPOWD**.

3.8. Reset the Module

The RESET_N can be used to reset the module. You can reset the module by driving the RESET_N to a low level voltage for more than 150ms and then releasing it.

Table 8: RESET_N Pin Description

Pin Name	Pin No.	Description	DC Characteristics	Comment
RESET_N	20	Reset the module	$V_{IHmax}=2.1V$ $V_{IHmin}=1.3V$ $V_{ILmax}=0.5V$	Pull-up to 1.8V internally. Active low.

The recommended circuit is similar to the PWRKEY control circuit. You can use open drain/collector driver or button to control the RESET_N.

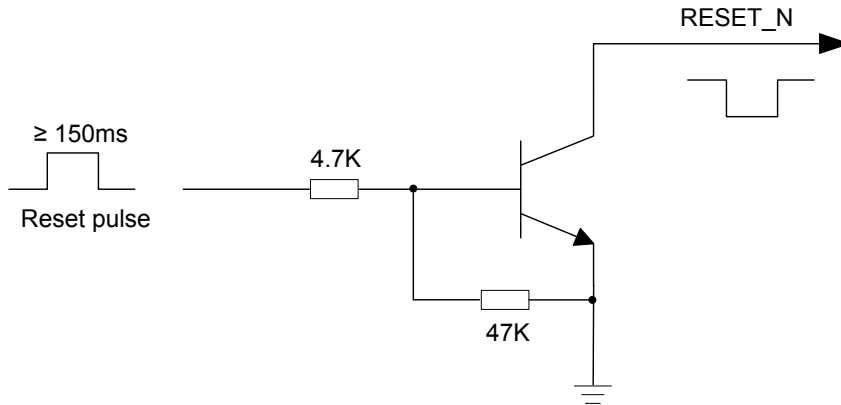

Figure 14: Reference Circuit of RESET_N by Using Driving Circuit

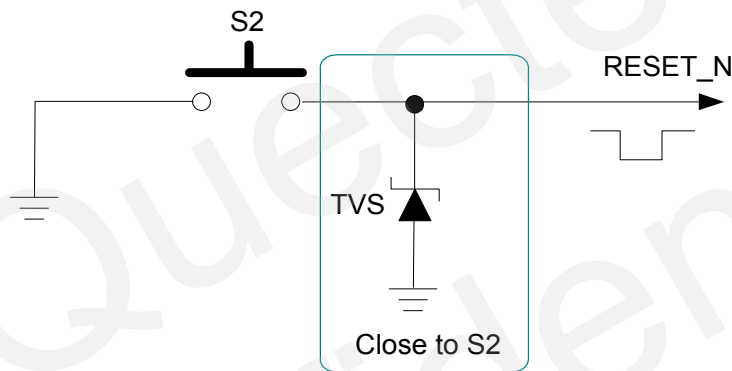

Figure 15: Reference Circuit of RESET_N by Using Button

The reset scenario is illustrated as the following figure.

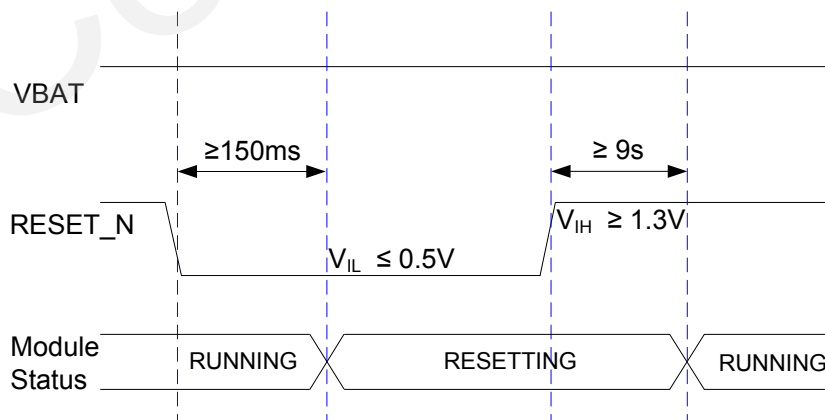

Figure 16: Timing of Resetting Module

NOTE

Use the RESET_N only when turning off the module by the command **AT+QPOWD** and the PWRKEY pin failed.

3.9. USIM Card Interface

The USIM card interface circuitry meets ETSI and IMT-2000 SIM interface requirements. Both 1.8V and 3.0V USIM cards are supported.

Table 9: Pin Definition of the USIM Interface

Pin Name	Pin No.	I/O	Description	Comment
USIM_VDD	14	PO	Power supply for USIM card	Either 1.8V or 3.0V is supported by the module automatically.
USIM_DATA	15	IO	Data signal of USIM card	
USIM_CLK	16	DO	Clock signal of USIM card	
USIM_RST	17	DO	Reset signal of USIM card	
USIM_GND	10		Specified ground for USIM card	

The reference circuit is illustrated as the following figure.

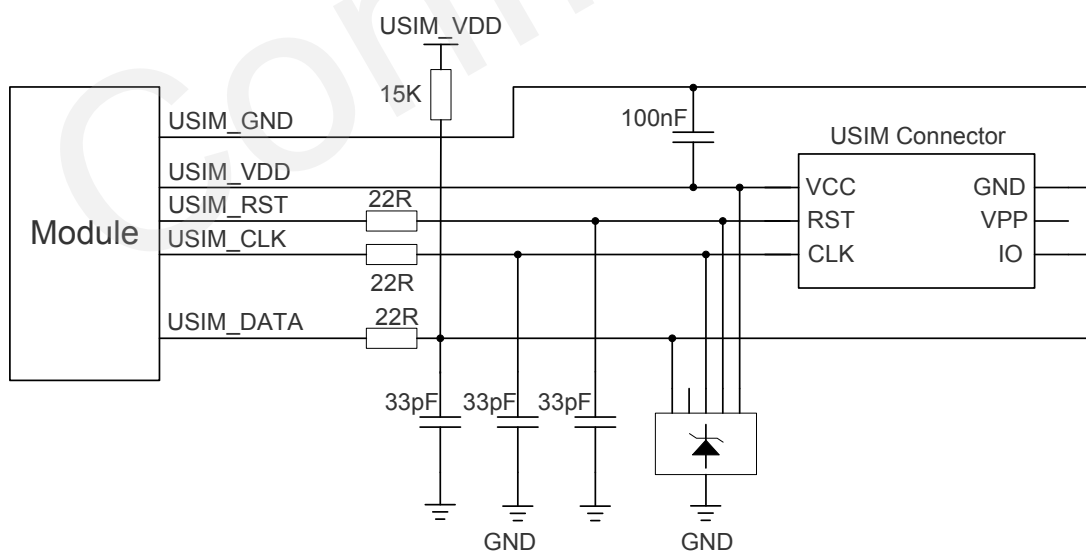

Figure 17: Reference Circuit of the 6 Pin USIM Card

In order to enhance the reliability and availability of the USIM card in your application, please follow the criteria below in the USIM circuit design:

- Keep layout of USIM card as close as possible to the module. Assure the length of the trace is less than 200mm.
- Keep USIM card signal away from RF and VBAT alignment.
- Assure the ground between module and USIM connector short and wide. Keep the width of ground and USIM_VDD no less than 0.5mm to maintain the same electric potential.
- To avoid cross-talk between USIM_DATA and USIM_CLK, keep them away with each other and shield them with surrounded ground.
- In order to offer good ESD protection, it is recommended to add TVS. The 22Ω resistors should be added in series between the module and the USIM card so as to suppress the EMI spurious transmission and enhance the ESD protection. The 33pF capacitors are used for filtering interference of EGSM900. Please note that the USIM peripheral circuit should be close to the USIM connector.
- The pull-up resistor on USIM_DATA line can improve anti-jamming capability when long layout trace and sensitive occasion is applied, and should be placed close to the USIM connector.

NOTE

Some AT commands are invalid when USIM card is not applied.

3.10. USB Interface

EC20 contains one integrated Universal Serial Bus (USB) transceiver which complies with the USB 2.0 specification and supports high-speed (480Mbps) and full-speed (12Mbps) mode. The USB interface is used for AT command, data transmission, GNSS NMEA sentences output, software debug and firmware upgrade. The following table shows the pin definition of USB interface.

Table 10: USB Pin Description

Pin Name	Pin No.	I/O	Description	Comment
USB_DP	69	IO	USB differential data bus (positive).	Require differential impedance of 90Ω.
USB_DM	70	IO	USB differential data bus (minus).	Require differential impedance of 90Ω.
USB_VBUS	71	PI	Used for detecting the USB connection.	3.0~5.25V Typical 5.0V
GND	72		Ground	

More details about the USB 2.0 specifications, please visit <http://www.usb.org/home>.

The USB interface is recommended to be reserved for firmware upgrade in your design. The following figure shows the recommended test points.

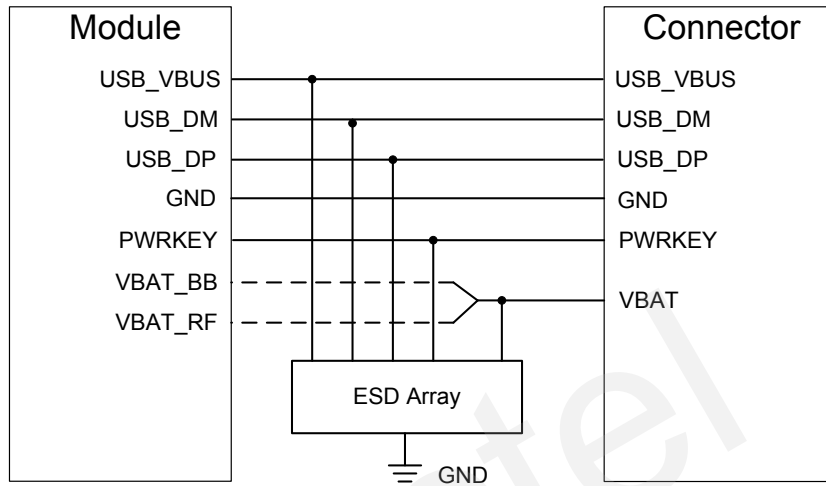

Figure 18: Test Points for Firmware Upgrade

In order to ensure the USB interface design corresponding with the USB 2.0 specification, please comply with the following principles.

- It is important to route the USB signal traces as differential pairs with total grounding. The impedance of USB differential trace is 90ohm.
- Do not route signal traces under crystals, oscillators, magnetic devices and RF signal traces. It is important to route the USB differential traces in inner-layer with ground shielding not only upper and lower layer but also right and left side.
- Pay attention to the influence of junction capacitance of ESD component on USB data lines. Typically, the capacitance value should be less than 2pF.
- Keep the ESD components as close as possible to the connector.
- Keep USB data test points traces short to avoid noise coupled on USB data lines. If possible, reserve 0R resistor on these two lines.

NOTE

EC20 module can only be used as a slave device.

3.11. UART Interface

The module provides two UART interfaces: main UART interface and debug UART interface. The following shows the different features.

- Main UART interface supports 9600, 19200, 38400, 57600, 115200, 230400, 460800, 921600bps baud rate, the default is 115200bps. This interface can be used for data transmission and AT communication.
- Debug UART interface supports 115200bps. It can be used for Linux console, log and GNSS NMEA output.

The following tables show the pin definition.

Table 11: Pin Definition of the UART Interface

Pin Name	Pin No.	I/O	Description	Comment
RI	62	DO	Ring indicator	1.8V power domain
DCD	63	DO	Data carrier detection	1.8V power domain
CTS	64	DO	Clear to send	1.8V power domain
RTS	65	DI	Request to send	1.8V power domain
DTR	66	DI	Sleep mode control	1.8V power domain
TXD	67	DO	Transmit data	1.8V power domain
RXD	68	DI	Receive data	1.8V power domain

Table 12: Pin Definition of the Debug UART Interface

Pin Name	Pin No.	I/O	Description	Comment
DBG_TXD	12	DO	Transmit data	1.8V power domain
DBG_RXD	11	DI	Receive data	1.8V power domain

The logic levels are described in the following table.

Table 13: Logic Levels of Digital I/O

Parameter	Min.	Max.	Unit
V_{IL}	-0.3	0.6	V
V_{IH}	1.2	2.0	V
V_{OL}	0	0.45	V
V_{OH}	1.35	1.8	V

Module provides 1.8V UART interface. A level translator should be used if your application is equipped with a 3.3V UART interface. A level translator TXS0108EPWR provided by **Texas Instrument** is recommended. The following figure shows the reference design.

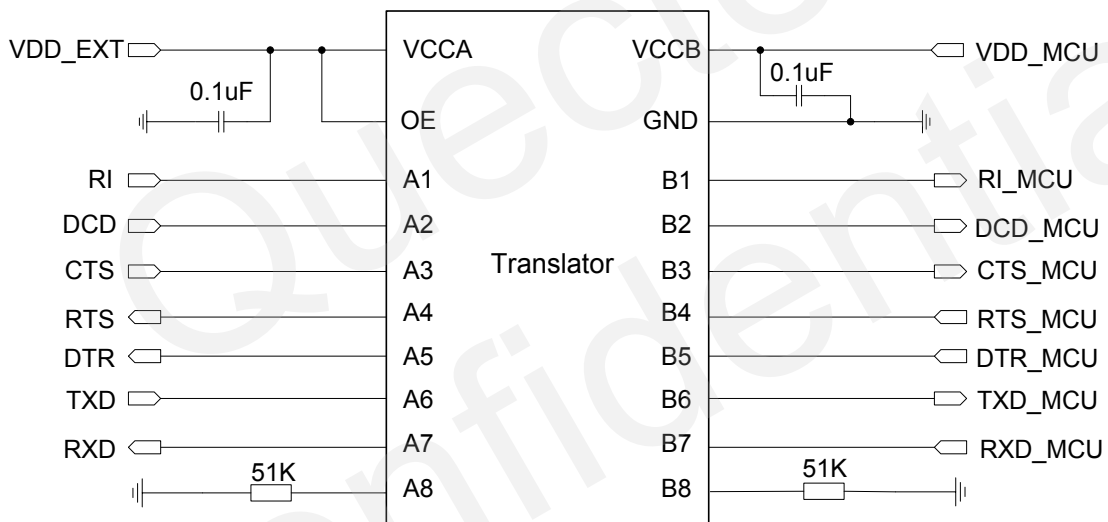

Figure 19: Reference Circuit with Translator Chip

Please visit <http://www.ti.com> for more information.

Another example with transistor translation circuit is shown as below. The circuit of dotted line can refer to the circuit of solid line. Please pay attention to direction of connection. Input dotted line of module should refer to input solid line of the module. Output dotted line of module should refer to output solid line of the module.

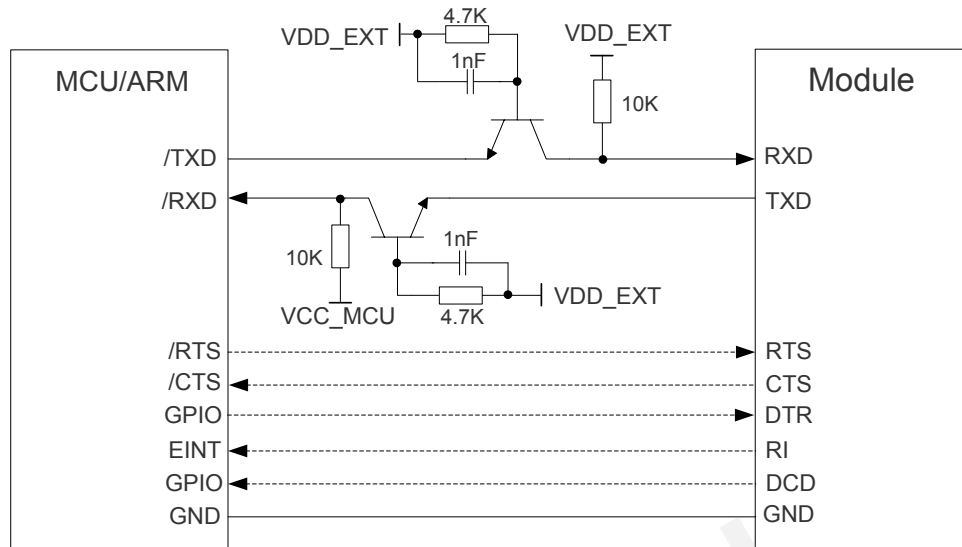

Figure 20: Reference Circuit with Transistor Circuit

NOTE

Transistor circuit solution is not suitable for high baud rate which is more than 460Kbps.

3.12. PCM and I2C Interface

EC20 provides one Pulse Code Modulation (PCM) digital interface for audio design, which supports the following modes:

- Primary mode (short sync, works as both master and slave)
- Auxiliary mode (long sync, works as master only)

In primary mode, the data is sampled on the falling edge of the PCM_CLK and transmitted on the rising edge; the PCM_SYNC falling edge represents the MSB. In this mode, PCM_CLK supports 128, 256, 512, 1024, 2048 and 4096kHz for different speech codec.

In auxiliary mode, the data is sampled on the falling edge of the PCM_CLK and transmitted on the rising edge; while the PCM_SYNC rising edge represents the MSB. In this mode, PCM interface operates with a 128kHz PCM_CLK and an 8kHz, 50% duty cycle PCM_SYNC only.

EC20 supports 8-bit A-law and μ -law, and also 16-bit linear data formats. The following figures show the primary mode's timing relationship with 8kHz PCM_SYNC and 2048kHz PCM_CLK and auxiliary mode's timing relationship with 8kHz PCM_SYNC and 128kHz PCM_CLK.

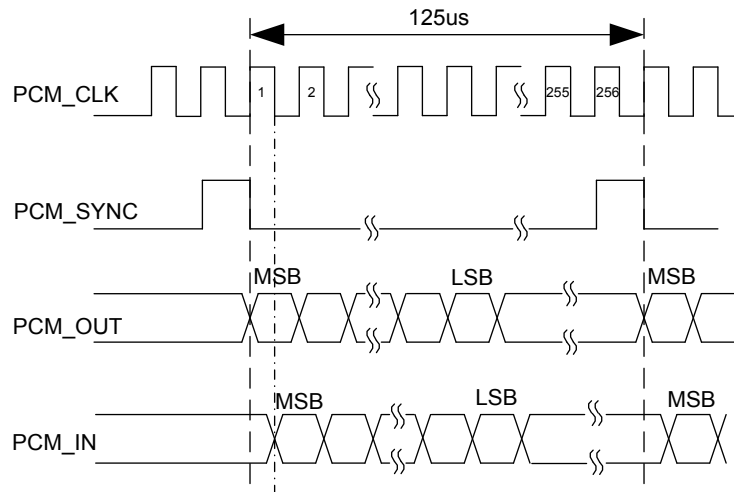

Figure 21: Primary Mode Timing

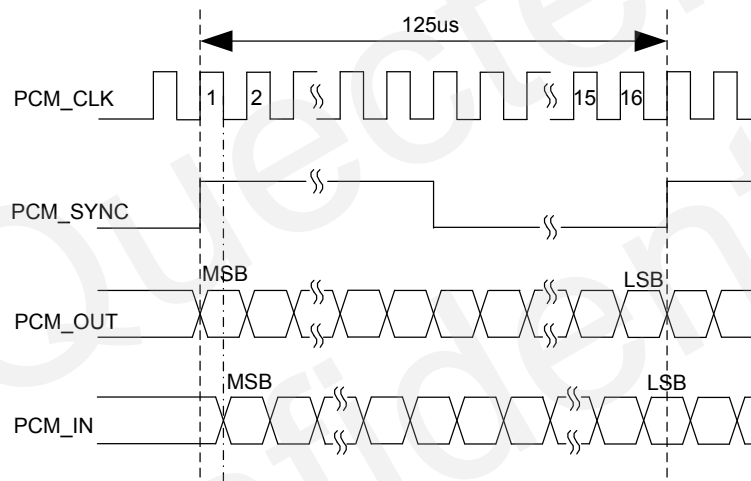

Figure 22: Auxiliary Mode Timing

The following table shows the pin definition of PCM and I2C interface which can be applied on audio codec design.

Table 14: Pin Definition of PCM and I2C Interface

Pin Name	Pin No.	I/O	Description	Comment
PCM_IN	24	DI	PCM data input	1.8V power domain
PCM_OUT	25	DO	PCM data output	1.8V power domain
PCM_SYNC	26	IO	PCM data frame sync signal	1.8V power domain

PCM_CLK	27	IO	PCM data bit clock	1.8V power domain
I2C_SCL	41	OD	I2C serial clock	Require external pull-up to 1.8V
I2C_SDA	42	OD	I2C serial data	Require external pull-up to 1.8V

Clock and mode can be configured by AT command, and the default configuration is master mode using short sync data format with 2048kHz PCM_CLK and 8kHz PCM_SYNC. In addition, EC20's firmware has integrated the configuration on ALC5616 application with I2C interface. Refer to **document [2]** about the command **AT+QDAI** for details.

The following figure shows the reference design of PCM interface with external codec IC.

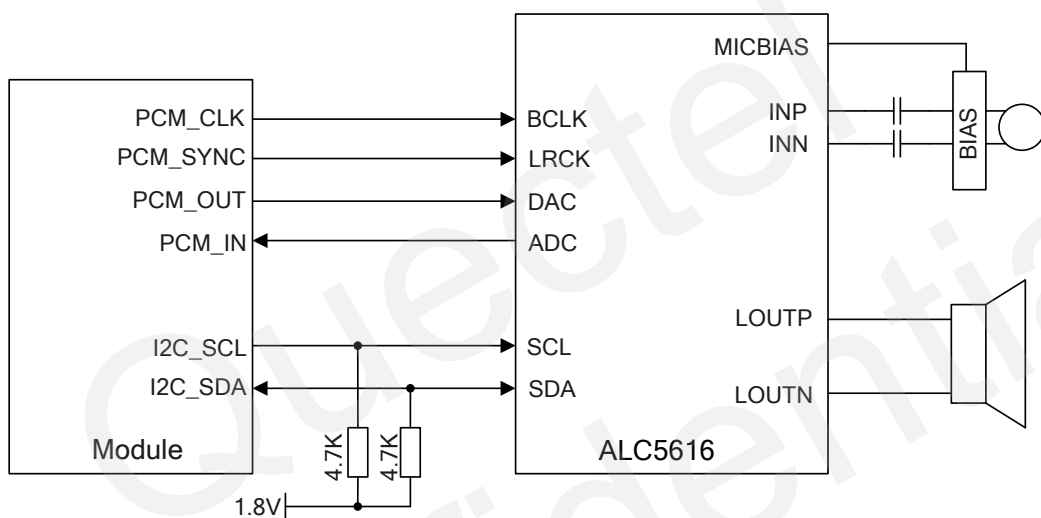

Figure 23: Reference Circuit of PCM Application with Audio Codec

NOTES

1. It is recommended to reserved RC (R=22Ω, C=22Pf) circuit on the PCM lines, especially for PCM_CLK.
2. EC20 works as a master device pertaining to I2C interface.

3.13. ADC Function

The module provides two analog-to-digital converters (ADC) to digitize the analog signal to 15-bit digital data such as battery voltage, temperature and so on. Using AT command **AT+QADC=0** can read the voltage value on ADC0 pin. Using AT command **AT+QADC=1** can read the voltage value on ADC1 pin. For more details of these AT commands, please refer to **document [1]**.

In order to improve the accuracy of ADC, the trace of ADC should be surrounded by ground.

Table 15: Pin Definition of the ADC

Pin Name	Pin No.	Description
ADC0	45	General purpose analog to digital converter
ADC1	44	General purpose analog to digital converter

The following table describes the characteristic of the ADC function.

Table 16: Characteristic of the ADC

Parameter	Min.	Typ.	Max.	Unit
ADC0 Voltage Range	0.3		VBAT_BB	V
ADC1 Voltage Range	0.3		VBAT_BB	V
ADC Resolution		15		bits

3.14. Network Status Indication

The network indication pins can be used to drive a network status indicator LED. The module provides two pins which are NET_MODE and NET_STATUS. The following tables describe pin definition and logic level changes in different network status.

Table 17: Pin Definition of Network Indicator

Pin Name	Pin No.	I/O	Description	Comment
NET_MODE	5	DO	Indicate the module network registration mode.	1.8V power domain
NET_STATUS	6	DO	Indicate the module network activity status.	1.8V power domain

Table 18: Working State of the Network Indicator

Pin Name	Status	Description
NET_MODE	Always High	Registered in LTE network
	Always Low	Others
NET_STATUS	Flicker slowly (200ms High/1800ms Low)	Network searching
	Flicker slowly (1800ms High/200ms Low)	Idle
	Flicker quickly (125ms High/125ms Low)	Data transfer is ongoing
	Always High	Voice calling

A reference circuit is shown in the following figure.

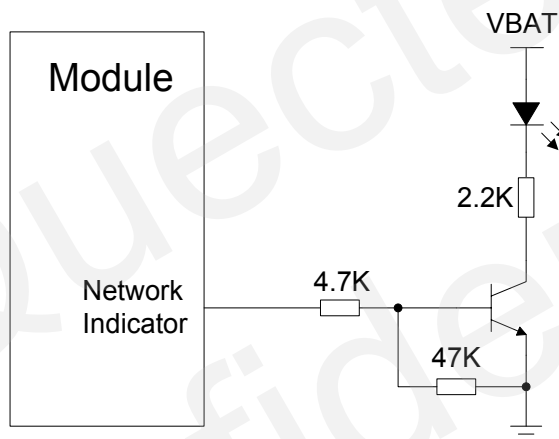

Figure 24: Reference Circuit of the Network Indicator

3.15. Operating Status Indication

The STATUS pin is an open drain output for indicating the module operation status. You can connect it to a GPIO of DTE with pulled up, or as LED indication circuit as below. When the module is turned on normally, the STATUS will present the low state. Otherwise, the STATUS will present high-impedance state.

Table 19: Pin Definition of STATUS

Pin Name	Pin No.	I/O	Description	Comment
STATUS	61	OD	Indicate the module operation status	Require external pull-up

The following figure shows different design circuit of STATUS, you can choose either one according to your application demands.

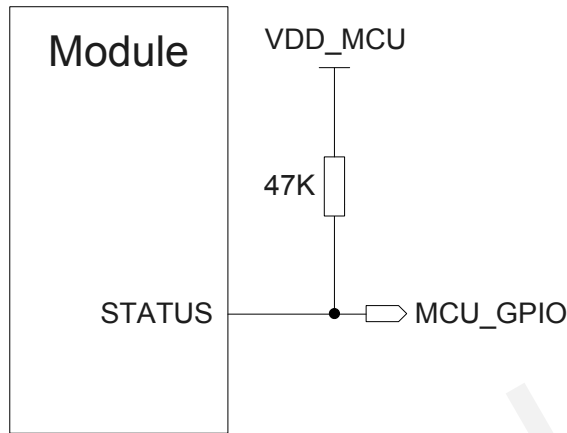

Figure 25: Reference Circuit of the STATUS

3.16. Behavior of the RI

You can use command **AT+QCFG="risignalttype", "physical"** to configure RI behavior:

No matter which port URC is presented on, URC will trigger the behavior on RI pin.

NOTE

URC can be output from UART port, USB AT port and USB modem port by command **AT+QURCCFG**. The default port is USB AT port.

In addition, RI behavior can be configured flexible. The default behavior of the RI is shown as below.

Table 20: Behavior of the RI

State	Response
Idle	RI keeps high level
URC	RI outputs 120ms low pulse when new URC returns

The RI behavior can be changed by command **AT+QCFG="urc/ri/ring"**, refer to **document [2]** for details.

4 GNSS Receiver

4.1. General Description

EC20 includes a fully integrated global navigation satellite system solution that supports gpsOne Gen8A of Qualcomm (GPS and GLONASS). Compared with GPS only, dual systems increase usable constellation, reduce coverage gaps and TTFF, and increase positioning accuracy, especially in rough urban environments.

EC20 works in standalone mode, allows device to demodulate GNSS assistance data, calculate position without any assistance from the network, and suitable for various application needing lowest-cost, accurate position determination. EC20 supports Qualcomm gpsOneXTRA technology (one kind of A-GNSS), which can download XTRA file from the internet server to enhance the TTFF. XTRA file contains predicted GPS and GLONASS satellites coordinates and clock biases valid for up to 7days. It is the best if XTRA file is downloaded every 1-2 days. And EC20 also supports SBAS (including WAAS, EGNOS and MSAS), which will improve fix accuracy.

EC20 provides power-saving solution named DPO (Dynamic Power Optimization), which attempts to turn off GNSS RF parts, reduces current consumption by 50% at most without impact on TTFF, thus extends battery life, and maximizes talk and standby time as well.

EC20 supports standard NMEA-0183 protocol, and outputs NMEA sentences with 1Hz via USB interface by default.

By default, EC20 GNSS engine is switched off, it has to be switched on with AT command. For more details about GNSS engine technology and configurations, please refer to **document [3]**.

4.2. GNSS Performance

The following table shows EC20 GNSS performance.

Table 21: GNSS Performance

Parameter	Description	Conditions	Typ.	Unit
Sensitivity (GNSS)	Cold start	Autonomous	-147	dBm
		Active antenna		dBm
	Reacquisition	Autonomous	-156	dBm
		Active antenna		dBm
	Tracking	Autonomous	-157	dBm
		Active antenna		dBm
TTFF (GNSS)	Cold start @open sky	Autonomous		s
		XTRA enabled		s
	Warm start @open sky	Autonomous		s
		XTRA enabled		s
	Hot start @open sky	Autonomous		s
		XTRA enabled		s
Accuracy (GNSS)	CEP-50	Autonomous @open sky		m

NOTES

1. Tracking sensitivity: the lowest GPS signal value at the antenna port for which the module can keep on positioning for 3 minutes.
2. Reacquisition sensitivity: the lowest GPS signal value at the antenna port for which the module can fix position again within 3 minutes after loss of lock.
3. Cold start sensitivity: the lowest GPS signal value at the antenna port for which the module fixes position within 3 minutes after executing cold start command.

4.3. Layout Guideline

The following layout guideline should be taken into account in your design.

- Maximize the distance between the GNSS antenna, the main antenna and Rx-diversity antenna.
- Noisy digital circuits such as the USIM card, USB interface, Camera module, Display connector and SD card should be away from the antenna.
- Use ground vias around the GNSS trace and sensitive analog signal traces to provide coplanar isolation and protection.
- Keep 50 ohm characteristic impedance of the ANT_GNSS trace.

Refer to **Chapter 5** for GNSS reference design and antenna consideration.

Quectel
Confidential

5 Antenna Interface

EC20 antenna interface includes a main antenna, an Rx-diversity antenna, which is used to resist the fall of signals caused by high speed movement and multipath effect, and a GNSS antenna. The antenna interface has an impedance of 50Ω.

5.1. Main/Rx-diversity Antenna Interface

5.1.1. Pin Definition

The main antenna and Rx-diversity antenna pins definition are shown below.

Table 22: Pin Definition of the RF Antenna

Pin Name	Pin No.	I/O	Description	Comment
ANT_MAIN	49	IO	Main antenna	50Ω impedance
ANT_DIV	35	AI	Receive diversity antenna	50Ω impedance

5.1.2. Operating Frequency

Table 23: The Module Operating Frequencies

3GPP Band	Transmit	Receive	Unit
B1	1920 ~ 1980	2110 ~ 2170	MHz
B2 (1900)	1850 ~ 1910	1930 ~ 1990	MHz
B3 (1800)	1710 ~ 1785	1805 ~ 1880	MHz
B4	1710 ~ 1755	2110 ~ 2155	MHz
B5 (850/BC0)	824 ~ 849	869 ~ 894	MHz
B7	2500 ~ 2570	2620 ~ 2690	MHz

B8 (900)	880 ~ 915	925 ~ 960	MHz
B12	699 ~ 716	728 ~ 746	MHz
B17	704 ~ 716	734 ~ 746	MHz
B20	832 ~ 862	791 ~ 821	MHz
B34	2010 ~ 2025	2010 ~ 2025	MHz
B38	2570 ~ 2620	2570 ~ 2620	MHz
B39	1880 ~ 1920	1880 ~ 1920	MHz
B40	2300 ~ 2400	2300 ~ 2400	MHz
B41	2496 ~ 2690	2496 ~ 2690	MHz

5.1.3. Reference Design

The reference design of ANT_MAIN and ANT_DIV antenna is shown as below. It should reserve a π -type matching circuit for better RF performance. The capacitors are not mounted by default.

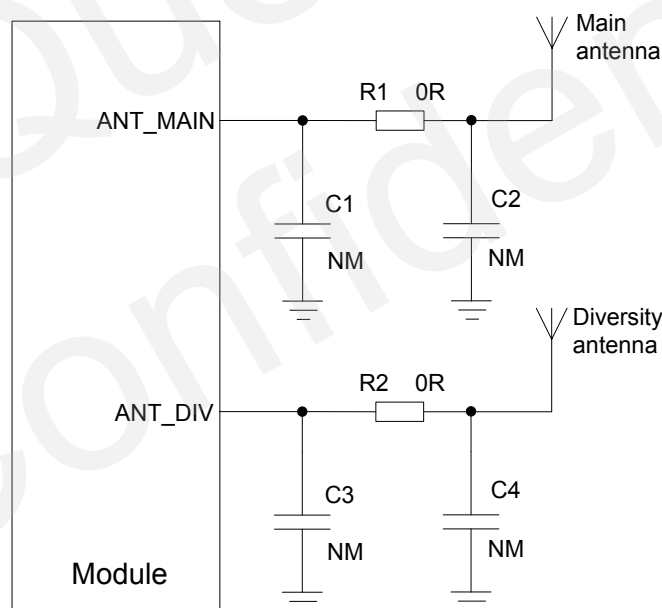

Figure 26: Reference Circuit of Antenna Interface

NOTE

Keep a proper distance between main antenna and Rx-diversity antenna to improve the receiving sensitivity.

5.2. GNSS Antenna Interface

The following tables show the GNSS antenna pin definition and frequency specification.

Table 24: Pin Definition of GNSS Antenna

Pin Name	Pin No.	I/O	Description	Comment
ANT_GNSS	47	AI	GNSS antenna	50Ω impedance

Table 25: GNSS Frequency

Type	Frequency	Unit
GPS	1575.42±1.023	MHz
GLONASS	1597.5~1605.8	MHz

The reference design of GNSS antenna is shown as below.

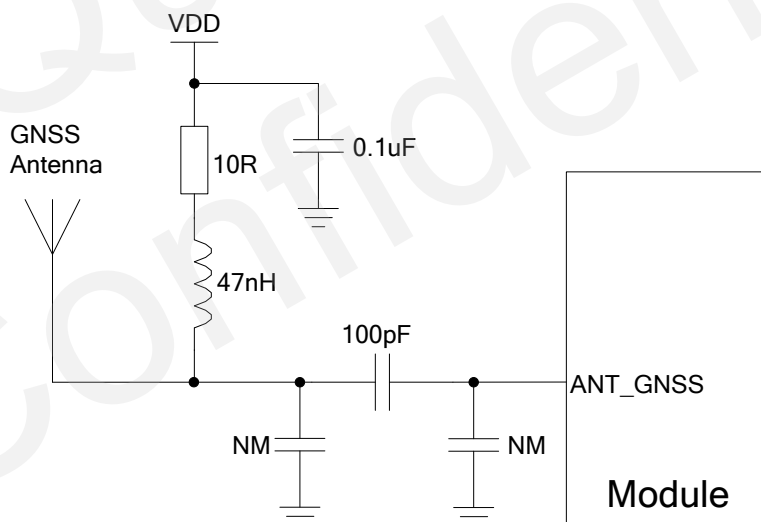

Figure 27: Reference Circuit of GNSS Antenna

NOTES

1. You can choose an external LDO to supply power according to the active antenna.
2. If you design it with passive antenna, the VDD circuit is not needed.

5.3. Antenna Installation

5.3.1. Antenna Requirement

The following table shows the requirement on main antenna, Rx-diversity antenna and GNSS antenna.

Table 26: Antenna Requirements

Type	Requirements
GNSS	Frequency range: 1565 - 1607MHz Polarization: RHCP or linear VSWR: < 2 (Typ.) Passive antenna gain: > 0dBi Active antenna noise figure: < 1.5dB Active antenna gain: > -2dBi Active antenna embedded LNA gain: 20dB (Typ.) Active antenna total gain: > 18dBi (Typ.)
GSM/WCDMA/TD-SCDMA/LTE	VSWR: ≤ 2 Gain (dBi): 1 Max Input Power (W): 50 Input Impedance (ohm): 50 Polarization Type: Vertical Cable Insertion Loss: < 1dB (GSM850/900, WCDMA B5/B8, LTE B5/B8/B12/B17/B20) Cable Insertion Loss: < 1.5dB (GSM1800/1900, WCDMA B1/B2/B3/B4, TD-SCDMAB34/B39, LTE B1/B2/B3/B4/B39) Cable insertion loss < 2dB (LTE B7/B38/B40/B41)

5.3.2. Install the Antenna with RF Connector

The following figure is the antenna installation with RF connector provided by HIROSE. The recommended RF connector is UF.L-R-SMT.

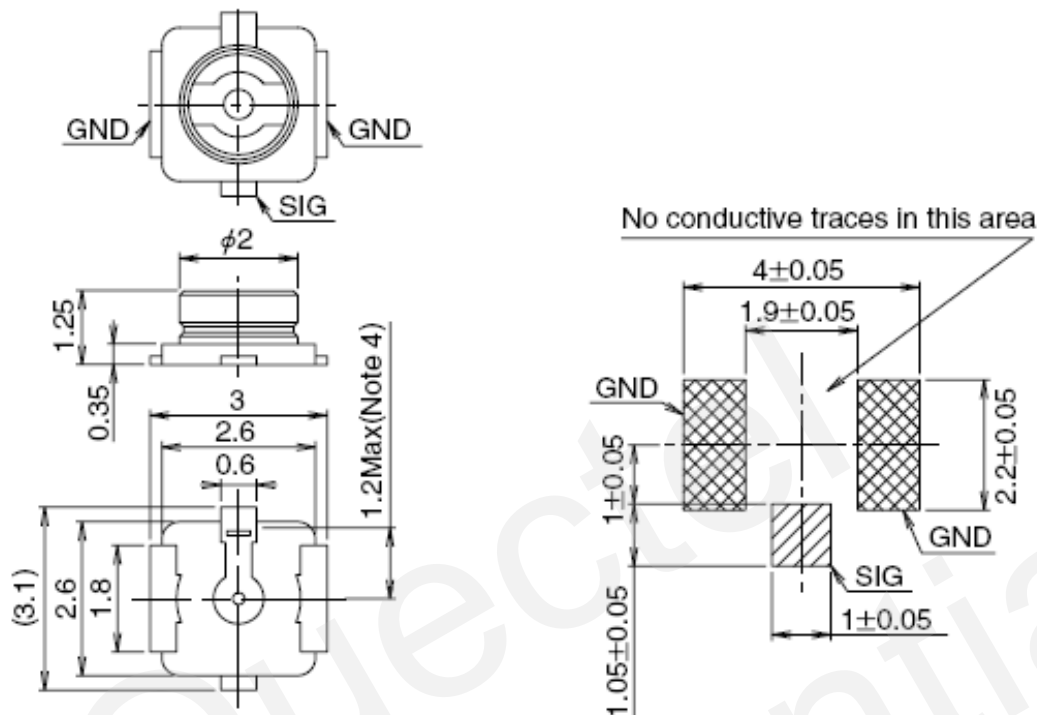

Figure 28: Dimensions of the UF.L-R-SMT Connector (Unit: mm)

You can use U.FL-LP serial connector listed in the following figure to match the UF.L-R-SMT.

	U.FL-LP-040	U.FL-LP-066	U.FL-LP(V)-040	U.FL-LP-062	U.FL-LP-088
Part No.					
Mated Height	2.5mm Max. (2.4mm Nom.)	2.5mm Max. (2.4mm Nom.)	2.0mm Max. (1.9mm Nom.)	2.4mm Max. (2.3mm Nom.)	2.4mm Max. (2.3mm Nom.)
Applicable cable	Dia. 0.81mm Coaxial cable	Dia. 1.13mm and Dia. 1.32mm Coaxial cable	Dia. 0.81mm Coaxial cable	Dia. 1mm Coaxial cable	Dia. 1.37mm Coaxial cable
Weight (mg)	53.7	59.1	34.8	45.5	71.7
RoHS	YES				

Figure 29: Mechanicals of UF.L-LP Connectors

The following figure describes the space factor of mated connector.

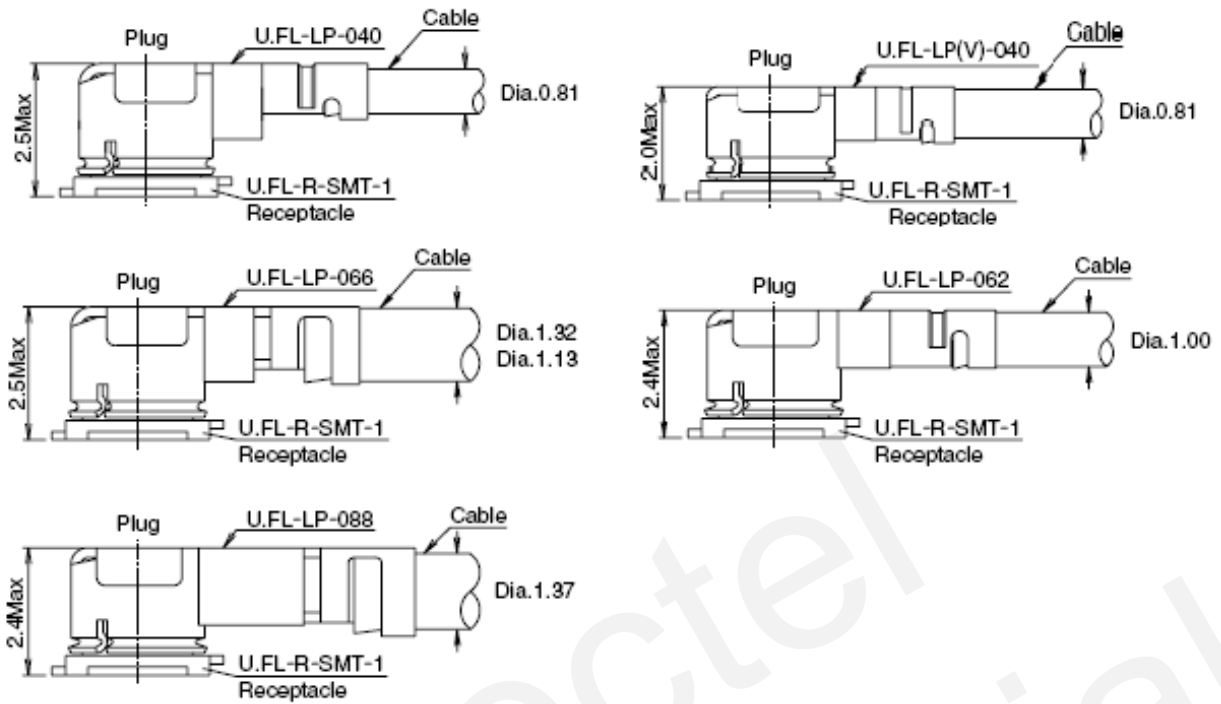

Figure 30: Space Factor of Mated Connector (Unit: mm)

For more details, please visit <http://www.hirose.com>.

6 Electrical, Reliability and Radio Characteristics

6.1. Absolute Maximum Ratings

Absolute maximum ratings for power supply and voltage on digital and analog pins of module are listed in the following table.

Table 27: Absolute Maximum Ratings

Parameter	Min.	Max.	Unit
VBAT_RF/VBAT_BB	-0.3	4.7	V
USB_VBUS	-0.3	5.5	V
Peak Current of VBAT_BB	0	0.8	A
Peak Current of VBAT_RF	0	1.8	A
Voltage at Digital Pins	-0.3	2.3	V
Voltage at ADC0	0	VBAT_BB	V
Voltage at ADC1	0	VBAT_BB	V

6.2. Power Supply Ratings

Table 28: The Module Power Supply Ratings

Parameter	Description	Conditions	Min.	Typ.	Max.	Unit
VBAT	VBAT_BB and VBAT_RF	Voltage must stay within the min/max values, including voltage drop, ripple and spikes.	3.3	3.8	4.3	V
	Voltage drop during transmitting burst	Maximum power control level on GSM850 and EGSM900.			400	mV
I _{VBAT}	Peak supply current (during transmission slot)	Maximum power control level on GSM850 and EGSM900.		1.8	2.0	A
USB_VBUS	USB detection		3.0	5.0	5.25	V

6.3. Operating Temperature

The operating temperature is listed in the following table.

Table 29: Operating Temperature

Parameter	Min.	Typ.	Max.	Unit
Normal Temperature	-35	25	75	°C
Restricted Operation	-40 ~ -35		75 ~ 85	°C
Storage Temperature	-45		90	°C

NOTE

The maximum surface temperature may be up to 100°C when module works at 85°C ambient temperature.

6.4. Current Consumption

The values of current consumption are shown below.

Table 30: EC20-A Current Consumption

Parameter	Description	Conditions	Typ.	Unit
I_{VBAT}	OFF state	Power down	20	μA
		AT+CFUN=0 (USB disconnected)	1.05	mA
		GSM DRX=2 (USB disconnected)	3.7	mA
	Sleep state	GSM DRX=9 (USB disconnected)	1.8	mA
		WCDMA DRX=6 (USB disconnected)	2.8	mA
		WCDMA DRX=9 (USB disconnected)	1.5	mA
		GSM850 4DL/1UL PCL=5	233	mA
		GSM850 3DL/2UL PCL=5	382	mA
		GSM850 2DL/3UL PCL=5	426	mA
	GPRS data transfer (GNSS off)	GSM850 1DL/4UL PCL=5	510	mA
		PCS1900 4DL/1UL PCL=0	198	mA
		PCS1900 3DL/2UL PCL=0	333	mA
		PCS1900 2DL/3UL PCL=0	385	mA
		PCS1900 1DL/4UL PCL=0	443	mA
		GSM850 4DL/1UL PCL=8	160	mA
		GSM850 3DL/2UL PCL=8	261	mA
		GSM850 2DL/3UL PCL=8	351	mA
	EDGE data transfer (GNSS off)	GSM850 1DL/4UL PCL=8	442	mA
		PCS1900 4DL/1UL PCL=2	154	mA
		PCS1900 3DL/2UL PCL=2	249	mA
		PCS1900 2DL/3UL PCL=2	333	mA

	PCS1900 1DL/4UL PCL=2	413	mA
WCDMA data transfer (GNSS off)	WCDMA B2 HSDPA @max power	496	mA
	WCDMA B2 HSUPA @max power	498	mA
	WCDMA B4 HSDPA @max power	442	mA
	WCDMA B4 HSUPA @max power	465	mA
	WCDMA B5 HSDPA @max power	464	mA
	WCDMA B5 HSUPA @max power	445	mA
	LTE data transfer (GNSS off)	LTE-FDD B2 @max power	584
LTE-FDD B4 @max power		564	mA
LTE-TDD B5 @max power		521	mA
LTE-TDD B12 @max power		432	mA
LTE-TDD B17 @max power		431	mA
GSM voice call	GSM850 @PCL=5	247	mA
	PCS1900 @PCL=0	207	mA
WCDMA voice call	WCDMA B2 @max power	470	mA
	WCDMA B4 @max power	429	mA
	WCDMA B5 @max power	450	mA

Table 31: EC20-C Current Consumption

Parameter	Description	Conditions	Typ.	Unit
I _{BAT}	OFF state	Power down	20	uA
	Sleep state	AT+CFUN=0 (USB disconnected)	0.9	mA
		GSM DRX=2 (USB disconnected)	3.3	mA
		GSM DRX=9 (USB disconnected)	1.8	mA
		WCDMA DRX=6 (USB disconnected)	2.3	mA
		WCDMA DRX=9 (USB disconnected)	1.4	mA
		LTE DRX=5 (USB disconnected)	5.2	mA

	LTE DRX=9 (USB disconnected)	1.6	mA
	AT+CFUN=0 (USB disconnected)	17	mA
	AT+CFUN=0 (USB connected)	32	mA
	GSM DRX=5 (USB disconnected)	20	mA
Idle state (GNSS off)	GSM DRX=5 (USB connected)	35	mA
	WCDMA DRX=6 (USB disconnected)	20	mA
	WCDMA DRX=6 (USB connected)	34	mA
	LTE DRX=6 (USB disconnected)	25	mA
	LTE DRX=6 (USB connected)	38	mA
	EGSM900 4DL/1UL PCL=5	285	mA
	EGSM900 3DL/2UL PCL=5	410	mA
	EGSM900 2DL/3UL PCL=5	511	mA
GPRS data transfer (GNSS off)	EGSM900 1DL/4UL PCL=5	598	mA
	DCS1800 4DL/1UL PCL=0	230	mA
	DCS1800 3DL/2UL PCL=0	318	mA
	DCS1800 2DL/3UL PCL=0	379	mA
	DCS1800 1DL/4UL PCL=0	440	mA
	EGSM900 4DL/1UL PCL=8	196	mA
	EGSM900 3DL/2UL PCL=8	298	mA
	EGSM900 2DL/3UL PCL=8	398	mA
EDGE data transfer (GNSS off)	EGSM900 1DL/4UL PCL=8	503	mA
	DCS1800 4DL/1UL PCL=2	186	mA
	DCS1800 3DL/2UL PCL=2	267	mA
	DCS1800 2DL/3UL PCL=2	346	mA
	DCS1800 1DL/4UL PCL=2	421	mA
WCDMA data transfer (GNSS off)	WCDMA B1 HSDPA @max power	550	mA
	WCDMA B1 HSUPA @max power	531	mA

	WCDMA B8 HSDPA @max power	458	mA
	WCDMA B8 HSUPA @max power	433	mA
	LTE-FDD B1 @max power	655	mA
	LTE-FDD B3 @max power	700	mA
LTE data transfer (GNSS off)	LTE-TDD B38 @max power	422	mA
	LTE-TDD B39 @max power	354	mA
	LTE-TDD B40 @max power	398	mA
	LTE-TDD B41 @max power	445	mA
GSM voice call	EGSM900 @PCL=5	285	mA
	DCS1800 @PCL=0	215	mA
WCDMA voice call	WCDMA B1 @max power	545	mA
	WCDMA B8 @max power	442	mA

Table 32: EC20-E Current Consumption

Parameter	Description	Conditions	Typ.	Unit	
I _{BAT}	OFF state	Power down	20	uA	
	Sleep state	AT+CFUN=0 (USB disconnected)		1.07	mA
		GSM DRX=2 (USB disconnected)		3.93	mA
		GSM DRX=9 (USB disconnected)		2.02	mA
		WCDMA DRX=6 (USB disconnected)		2.99	mA
		WCDMA DRX=9 (USB disconnected)		1.64	mA
		AT+CFUN=0 (USB disconnected)		19	mA
	Idle state (GNSS off)	AT+CFUN=0 (USB connected)		34	mA
		GSM DRX=5 (USB disconnected)		23	mA
		GSM DRX=5 (USB connected)		38	mA
		WCDMA DRX=6 (USB disconnected)		21	mA

	WCDMA DRX=6 (USB connected)	36	mA
	LTE DRX=6 (USB disconnected)	26	mA
	LTE DRX=6 (USB connected)	39	mA
	GSM850 4DL/1UL PCL=5	295	mA
	GSM850 3DL/2UL PCL=5	490	mA
	GSM850 2DL/3UL PCL=5	550	mA
	GSM850 1DL/4UL PCL=5	638	mA
	EGSM900 4DL/1UL PCL=5	270	mA
	EGSM900 3DL/2UL PCL=5	452	mA
	EGSM900 2DL/3UL PCL=5	523	mA
GPRS data transfer (GNSS off)	EGSM900 1DL/4UL PCL=5	615	mA
	DCS1800 4DL/1UL PCL=0	266	mA
	DCS1800 3DL/2UL PCL=0	427	mA
	DCS1800 2DL/3UL PCL=0	583	mA
	DCS1800 1DL/4UL PCL=0	728	mA
	PCS1900 4DL/1UL PCL=0	266	mA
	PCS1900 3DL/2UL PCL=0	434	mA
	PCS1900 2DL/3UL PCL=0	586	mA
	PCS1900 1DL/4UL PCL=0	736	mA
	GSM850 4DL/1UL PCL=8	208	mA
	GSM850 3DL/2UL PCL=8	317	mA
	GSM850 2DL/3UL PCL=8	418	mA
EDGE data transfer (GNSS off)	GSM850 1DL/4UL PCL=8	533	mA
	EGSM900 4DL/1UL PCL=8	190	mA
	EGSM900 3DL/2UL PCL=8	295	mA
	EGSM900 2DL/3UL PCL=8	402	mA
	EGSM900 1DL/4UL PCL=8	506	mA

	DCS1800 4DL/1UL PCL=2	200	mA
	DCS1800 3DL/2UL PCL=2	313	mA
	DCS1800 2DL/3UL PCL=2	422	mA
	DCS1800 1DL/4UL PCL=2	531	mA
	PCS1900 4DL/1UL PCL=2	200	mA
	PCS1900 3DL/2UL PCL=2	311	mA
	PCS1900 2DL/3UL PCL=2	421	mA
	PCS1900 1DL/4UL PCL=2	523	mA
WCDMA data transfer (GNSS off)	WCDMA B1 HSDPA @max power	463	mA
	WCDMA B1 HSUPA @max power	470	mA
	WCDMA B5 HSDPA @max power	419	mA
	WCDMA B5 HSUPA @max power	446	mA
	WCDMA B8 HSDPA @max power	400	mA
	WCDMA B8 HSUPA @max power	428	mA
LTE data transfer (GNSS off)	LTE-FDD B1 @max power	546	mA
	LTE-FDD B3 @max power	584	mA
	LTE-FDD B5 @max power	520	mA
	LTE-FDD B7 @max power	558	mA
	LTE-FDD B8 @max power	558	mA
	LTE-FDD B20 @max power	524	mA
GSM voice call	GSM850 @PCL=5	289	mA
	EGSM900 @PCL=5	259	mA
	DCS1800 @PCL=0	255	mA
	PCS1900 @PCL=0	265	mA
WCDMA voice call	WCDMA B1 @max power	519	mA
	WCDMA B5 @max power	435	mA
	WCDMA B8 @max power	426	mA

6.5. RF Output Power

The following table shows the RF output power of EC20 module.

Table 33: Conducted RF Output Power

Frequency	Max.	Min.
GSM850/EGSM900	33dBm±2dB	5dBm±5dB
DCS1800/PCS1900	30dBm±2dB	0dBm±5dB
GSM850/EGSM900 (8-PSK)	27dBm±3dB	5dBm±5dB
DCS1800/PCS1900 (8-PSK)	26dBm±3dB	0dBm±5dB
WCDMA B1/B2/B4/B5/B8	24dBm+1/-3dB	<-50dBm
TD-SCDMA B34/B39	24dBm+1/-3dB	<-50dBm
LTE FDD B1/B2/B3/B4/B5/B7/B8/B12/B17/B20	23dBm±2dB	<-44dBm
LTE TDD B38/B39/B40/B41	23dBm±2dB	<-44dBm

NOTE

In GPRS 4 slots TX mode, the max output power is reduced by 2.5dB. This design conforms to the GSM specification as described in Chapter 13.16 of 3GPP TS 51.010-1.

6.6. RF Receiving Sensitivity

The following table shows the conducted RF receiving sensitivity of EC20 module.

Table 34: EC20-A Conducted RF Receiving Sensitivity

Frequency	Receive Sensitivity (Typ.)
GSM850	-111dBm
DCS1800	-110dBm
WCDMA B2	-111dBm

WCDMA B4	-111dBm
WCDMA B5	-112dBm
LTE FDD B2 (20M)	-96dBm
LTE FDD B4 (20M)	-96dBm
LTE TDD B5 (10M)	-98dBm
LTE TDD B12 (10M)	-99dBm
LTE TDD B17 (10M)	-99dBm

Table 35: EC20-C Conducted RF Receiving Sensitivity

Frequency	Receive Sensitivity (Typ.)
EGSM900	-109.5dBm
DCS1800	-109dBm
WCDMA B1	-110dBm
WCDMA B8	-110dBm
LTE FDD B1 (20M)	-95dBm
LTE FDD B3 (20M)	-94dBm
LTE TDD B38 (20M)	-94dBm
LTE TDD B39 (20M)	-94dBm
LTE TDD B40 (20M)	-94dBm
LTE FDD B41 (20M)	-93.5dBm

Table 36: EC20-E Conducted RF Receiving Sensitivity

Frequency	Receive Sensitivity (Typ.)
GSM850	-111dBm
EGSM900	-110dBm
DCS1800	-109dBm

PCS1900	-109dBm
WCDMA B1	-110dBm
WCDMA B5	-112dBm
WCDMA B8	-111dBm
LTE FDD B1 (20M)	-97dBm
LTE FDD B3 (20M)	-96dBm
LTE FDD B5 (20M)	-99dBm
LTE FDD B7 (20M)	-97dBm
LTE FDD B8 (20M)	-98dBm
LTE FDD B20 (20M)	-96dBm

6.7. Electrostatic Discharge

The module is not protected against electrostatics discharge (ESD) in general. Consequently, it is subject to ESD handling precautions that typically apply to ESD sensitive components. Proper ESD handling and packaging procedures must be applied throughout the processing, handling and operation of any application that incorporates the module.

The following table shows the module electrostatics discharge characteristics.

Table 37: Electrostatics Discharge Characteristics

Tested Points	Contact Discharge	Air Discharge	Unit
VBAT, GND	±5	±10	kV
All Antenna Interfaces	±4	±8	kV
Other Interfaces	±0.5	±1	kV

7 Mechanical Dimensions

This chapter describes the mechanical dimensions of the module. All dimensions are measured in mm.

7.1. Mechanical Dimensions of the Module

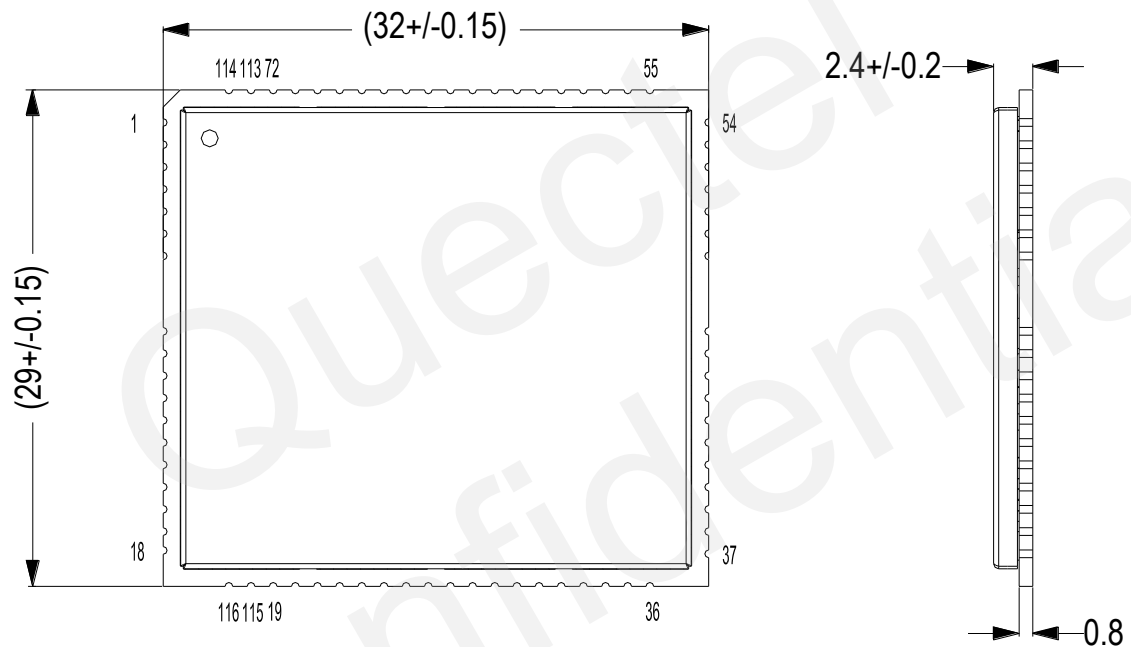

Figure 31: Module Top and Side Dimensions

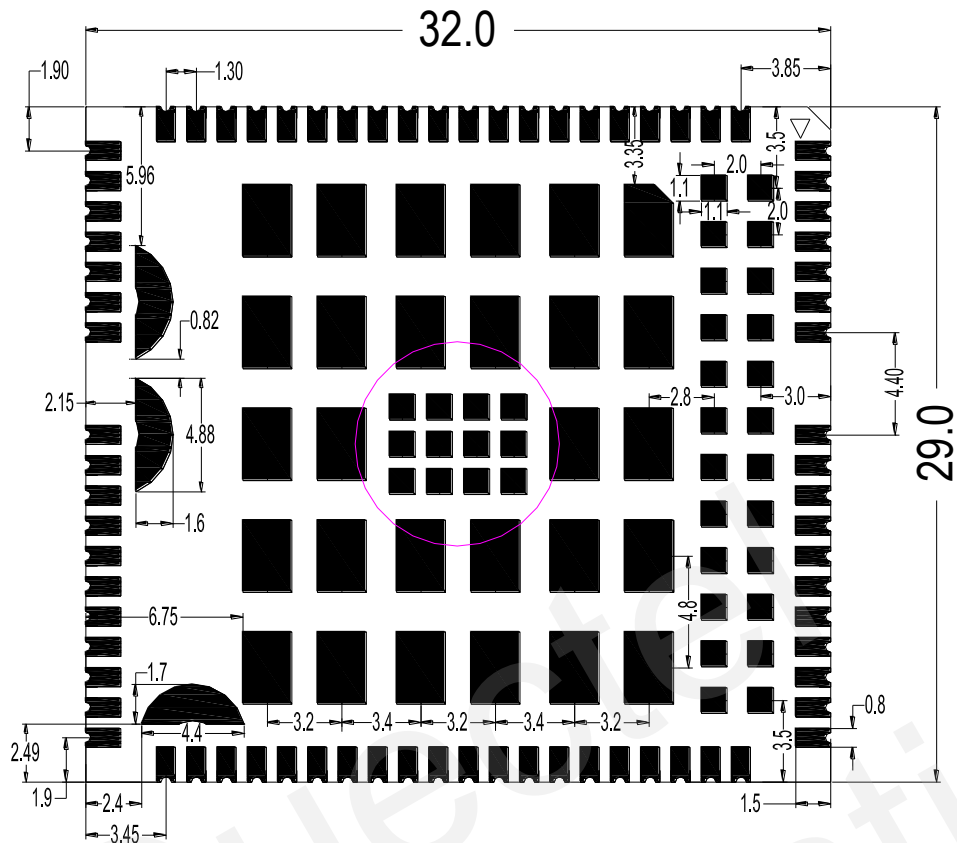

Figure 32: Module Bottom Dimensions (Bottom View)

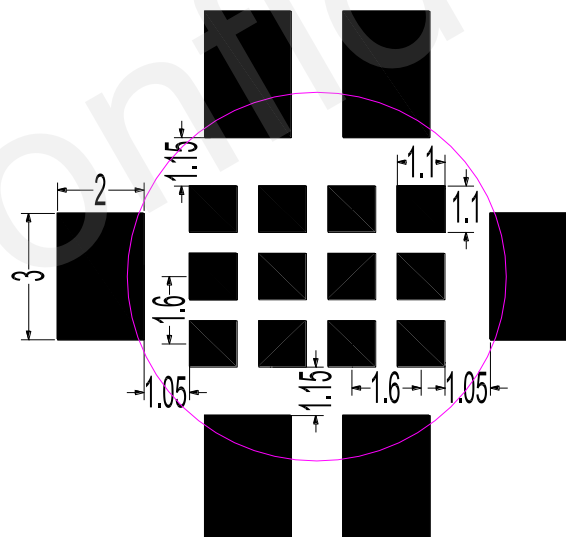

Figure 33: Bottom Pads Dimensions (Bottom View)

7.2. Footprint of Recommendation

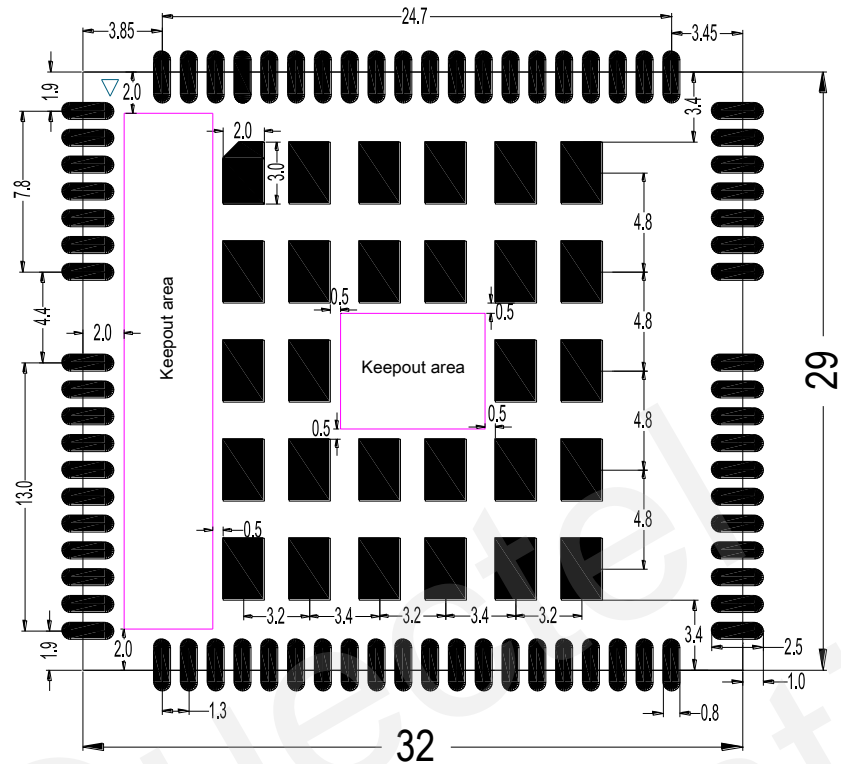

Figure 34: Recommended Footprint (Top View)

NOTE

In order to maintain the module, keep about 3mm between the module and other components in the host PCB.

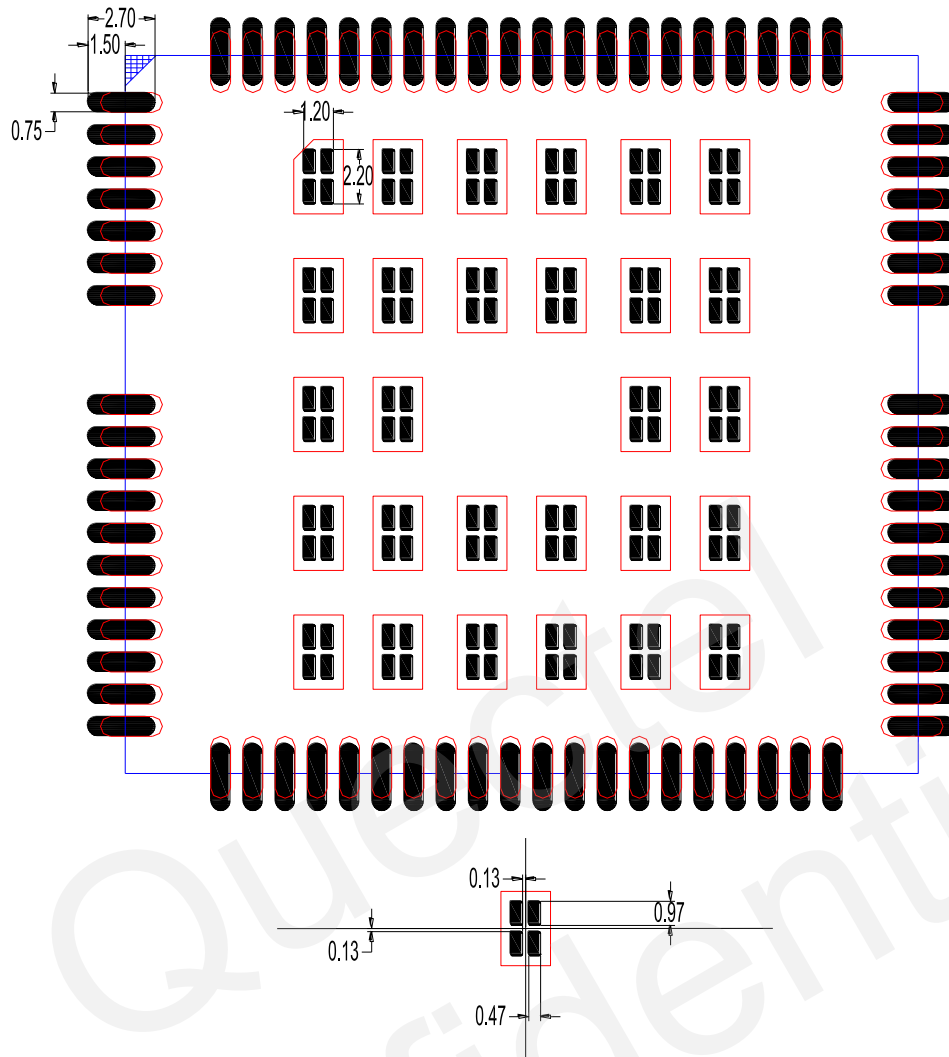

Figure 35: Recommended Stencil

NOTES

1. The thickness of stencil for the pads at the bottom of module is recommended as 0.18mm, and the thickness of LCC pins is recommended as 0.2mm.
2. For better SMT solder, the GND pad at the bottom of the module is divided into four small pads.
3. The red areas are recommended footprint shown in Figure 34.

If you design with pins 117~140, the following footprint is recommended.

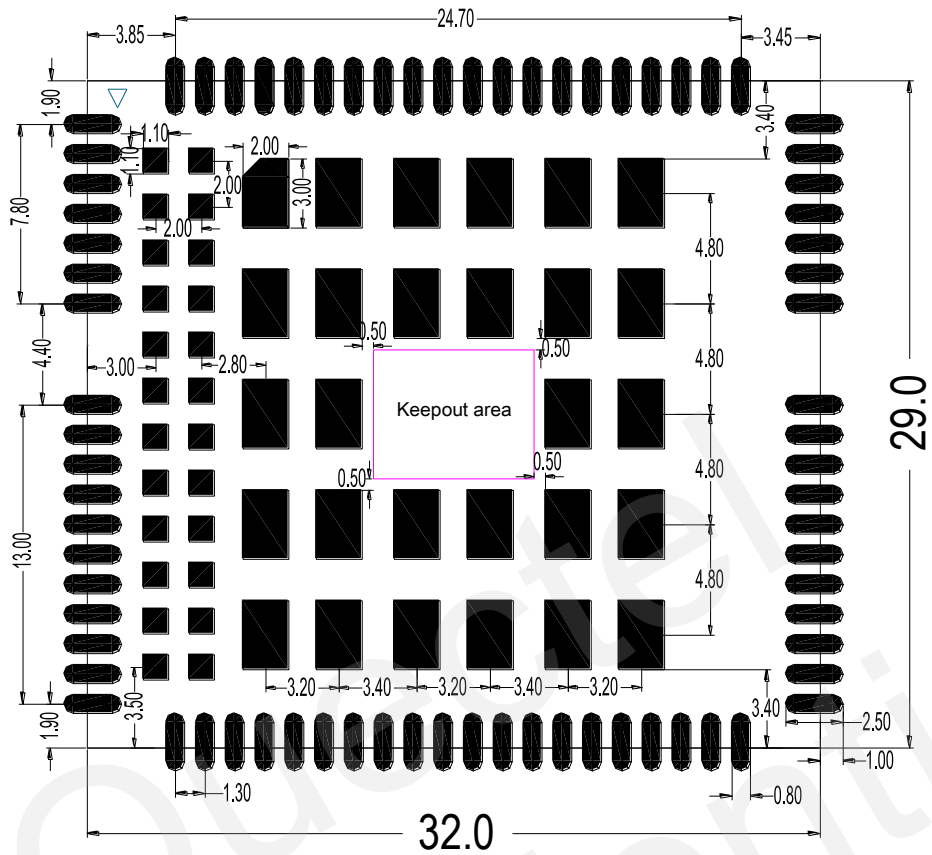

Figure 36: Recommended Footprint with Pins 117~140

7.3. Top View of the Module



Figure 37: Top View of the Module

7.4. Bottom View of the Module

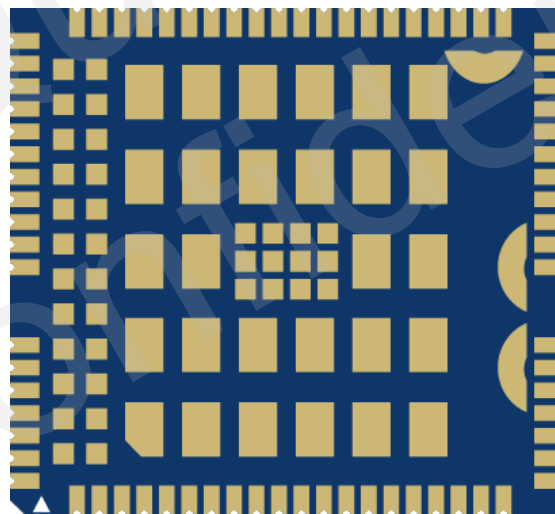

Figure 38: Bottom View of the Module

8 Storage and Manufacturing

8.1. Storage

EC20 is stored in the vacuum-sealed bag. The restriction of storage condition is shown as below.

Shelf life in sealed bag is 12 months at $< 40^{\circ}\text{C}/90\%\text{RH}$.

After this bag is opened, devices that will be subjected to reflow solder or other high temperature process must be:

- Mounted within 72 hours at factory conditions of $\leq 30^{\circ}\text{C}/60\%\text{RH}$.
- Stored at $<10\% \text{RH}$.

Devices require bake before mounting, if:

- Humidity indicator card is $>10\%$ when read $23^{\circ}\text{C}\pm 5^{\circ}\text{C}$.
- Mounted for more than 72 hours at factory conditions of $\leq 30^{\circ}\text{C}/60\% \text{RH}$.

If baking is required, devices may be baked for 48 hours at $125^{\circ}\text{C}\pm 5^{\circ}\text{C}$.

NOTE

As plastic container cannot be subjected to high temperature, module needs to be taken out from container to high temperature (125°C) bake. If shorter bake times are desired, please refer to IPC/JEDECJ-STD-033 for bake procedure.

8.2. Manufacturing and Welding

The squeegee should push the paste on the surface of the stencil that makes the paste fill the stencil openings and penetrate to the PCB. The force on the squeegee should be adjusted so as to produce a clean stencil surface on a single pass. To ensure the module soldering quality, the thickness of stencil at the hole of the module pads should be 0.18mm. For details, please refer to **document [4]**.

It is suggested that peak reflow temperature is 235 ~ 245°C (for SnAg3.0Cu0.5 alloy). Absolute max reflow temperature is 260°C. To avoid damage to the module when it was repeatedly heated, it is suggested that the module should be mounted after the first panel has been reflowed. The following picture is the actual diagram which we have operated.

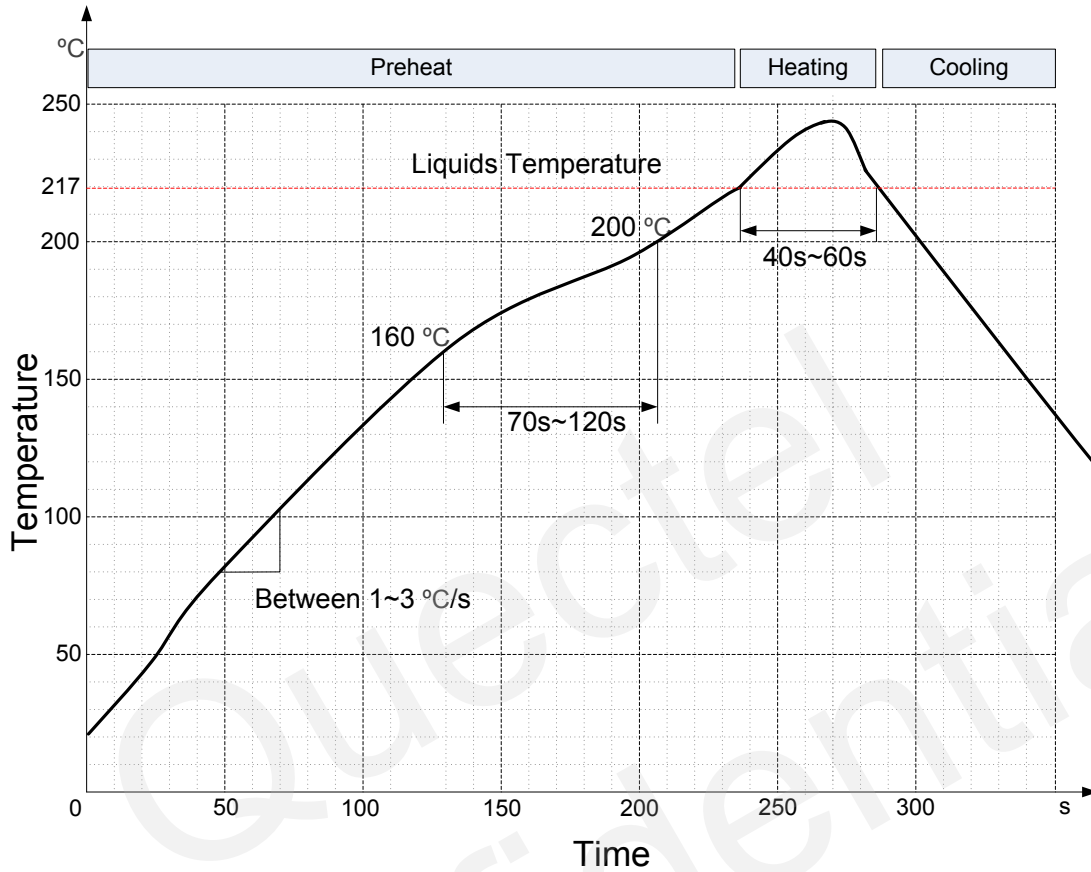

Figure 39: Liquids Temperature

8.3. Packaging

EC20 is packaged in the tap and reel carriers. One reel is 11.53m length and contains 250pcs modules. The figure below shows the package details, measured in mm.

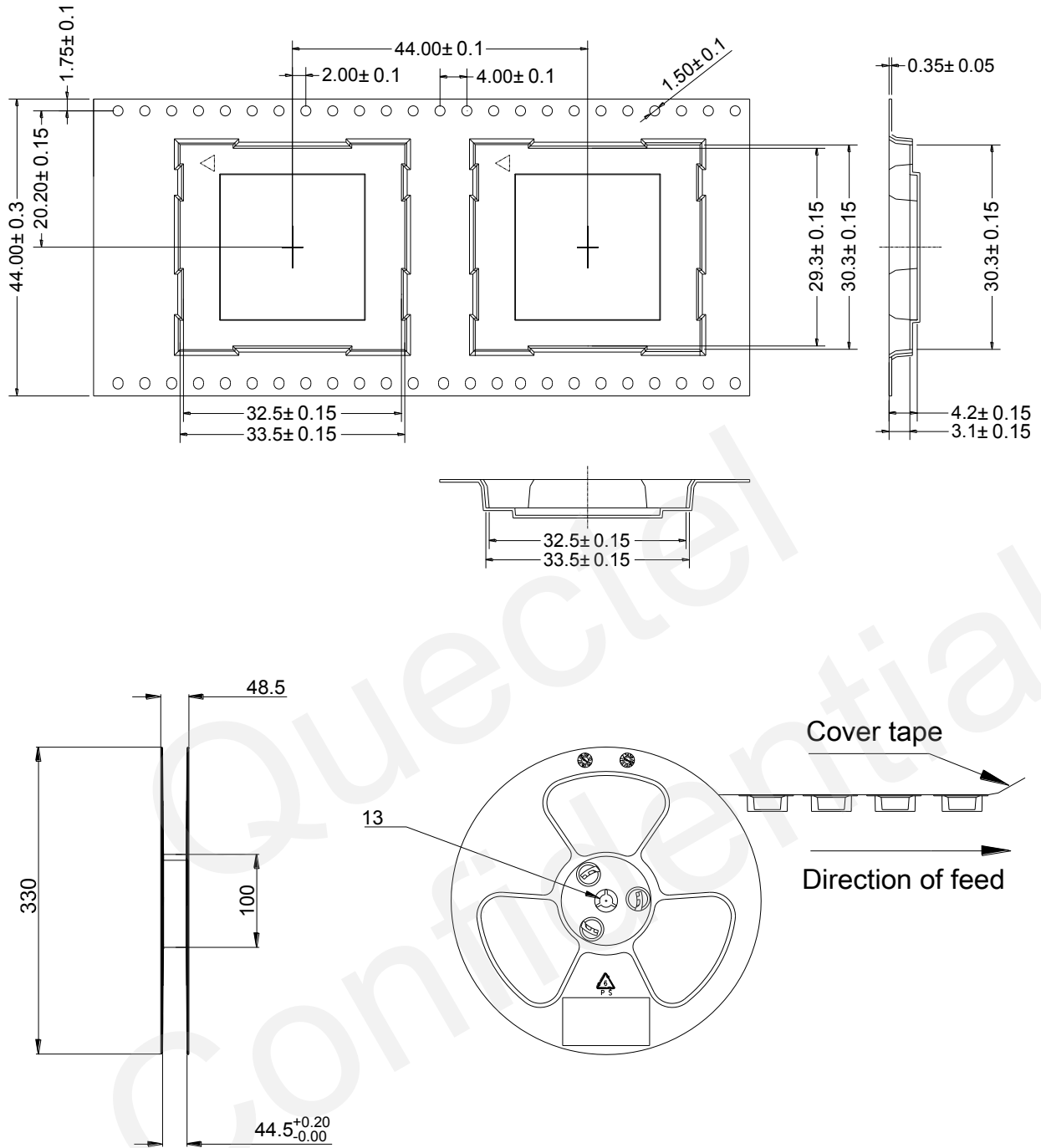

Figure 40: Carrier Tape

9 Appendix A Reference

Table 38: Related Documents

SN	Document Name	Remark
[1]	Quectel_EC20_Power_Management_Application_Note	EC20 Power Management Application Note
[2]	Quectel_EC20_AT_Commands_Manual	EC20 AT Commands Manual
[3]	Quectel_EC20_GNSS_AT_Commands_Manual	EC20 GNSS AT Commands Manual
[4]	Quectel_Module_Secondary_SMT_User_Guide	Module Secondary SMT User Guide

Table 39: Terms and Abbreviations

Abbreviation	Description
AMR	Adaptive Multi-rate
bps	Bits Per Second
CHAP	Challenge Handshake Authentication Protocol
CS	Coding Scheme
CSD	Circuit Switched Data
CTS	Clear To Send
DC-HSPA+	Dual-carrier High Speed Packet Access
DFOTA	Delta Firmware Upgrade Over The Air
DL	Downlink
DTR	Data Terminal Ready
DTX	Discontinuous Transmission

EFR	Enhanced Full Rate
EGSM	Extended GSM900 band (includes standard GSM900 band)
ESD	Electrostatic Discharge
FDD	Frequency Division Duplex
FR	Full Rate
GLONASS	GLOBALnaya NAVigatsionnaya Sputnikovaya Sistema, the Russian Global Navigation Satellite System
GMSK	Gaussian Minimum Shift Keying
GNSS	Global Navigation Satellite System
GPS	Global Positioning System
GSM	Global System for Mobile Communications
HR	Half Rate
HSPA	High Speed Packet Access
HSDPA	High Speed Downlink Packet Access
HSUPA	High Speed Uplink Packet Access
I/O	Input/Output
Inorm	Normal Current
LED	Light Emitting Diode
LNA	Low Noise Amplifier
LTE	Long Term Evolution
MIMO	Multiple Input Multiple Output
MO	Mobile Originated
MS	Mobile Station (GSM engine)
MT	Mobile Terminated
PAP	Password Authentication Protocol
PCB	Printed Circuit Board

PDU	Protocol Data Unit
PPP	Point-to-Point Protocol
QAM	Quadrature Amplitude Modulation
QPSK	Quadrature Phase Shift Keying
RF	Radio Frequency
RHCP	Right Hand Circularly Polarized
Rx	Receive
SIM	Subscriber Identification Module
SMS	Short Message Service
TDD	Time Division Duplexing
TDMA	Time Division Multiple Access
TD-SCDMA	Time Division-Synchronous Code Division Multiple Access
TX	Transmitting Direction
UL	Uplink
UMTS	Universal Mobile Telecommunications System
URC	Unsolicited Result Code
USIM	Universal Subscriber Identity Module
USSD	Unstructured Supplementary Service Data
V _{max}	Maximum Voltage Value
V _{norm}	Normal Voltage Value
V _{min}	Minimum Voltage Value
V _{IH} max	Maximum Input High Level Voltage Value
V _{IH} min	Minimum Input High Level Voltage Value
V _{IL} max	Maximum Input Low Level Voltage Value
V _{IL} min	Minimum Input Low Level Voltage Value

$V_{I\max}$	Absolute Maximum Input Voltage Value
$V_{I\min}$	Absolute Minimum Input Voltage Value
$V_{OH\max}$	Maximum Output High Level Voltage Value
$V_{OH\min}$	Minimum Output High Level Voltage Value
$V_{OL\max}$	Maximum Output Low Level Voltage Value
$V_{OL\min}$	Minimum Output Low Level Voltage Value
VSWR	Voltage Standing Wave Ratio
WCDMA	Wideband Code Division Multiple Access

Quectel
Confidential

10 Appendix B GPRS Coding Scheme

Table 40: Description of Different Coding Schemes

Scheme	CS-1	CS-2	CS-3	CS-4
Code Rate	1/2	2/3	3/4	1
USF	3	3	3	3
Pre-coded USF	3	6	6	12
Radio Block excl.USF and BCS	181	268	312	428
BCS	40	16	16	16
Tail	4	4	4	-
Coded Bits	456	588	676	456
Punctured Bits	0	132	220	-
Data Rate Kb/s	9.05	13.4	15.6	21.4

11 Appendix C GPRS Multi-slot Class

Twenty-nine classes of GPRS multi-slot modes are defined for MS in GPRS specification. Multi-slot classes are product dependant, and determine the maximum achievable data rates in both the uplink and downlink directions. Written as 3+1 or 2+2, the first number indicates the amount of downlink timeslots, while the second number indicates the amount of uplink timeslots. The active slots determine the total number of slots the GPRS device can use simultaneously for both uplink and downlink communications.

The description of different multi-slot classes is shown in the following table.

Table 41: GPRS Multi-slot Classes

Multislot Class	Downlink Slots	Uplink Slots	Active Slots
1	1	1	2
2	2	1	3
3	2	2	3
4	3	1	4
5	2	2	4
6	3	2	4
7	3	3	4
8	4	1	5
9	3	2	5
10	4	2	5
11	4	3	5
12	4	4	5

12 Appendix D EDGE Modulation and Coding Scheme

Table 42: EDGE Modulation and Coding Scheme

Coding Scheme	Modulation	Coding Family	1 Timeslot	2 Timeslot	4 Timeslot
CS-1:	GMSK	/	9.05kbps	18.1kbps	36.2kbps
CS-2:	GMSK	/	13.4kbps	26.8kbps	53.6kbps
CS-3:	GMSK	/	15.6kbps	31.2kbps	62.4kbps
CS-4:	GMSK	/	21.4kbps	42.8kbps	85.6kbps
MCS-1	GMSK	C	8.80kbps	17.60kbps	35.20kbps
MCS-2	GMSK	B	11.2kbps	22.4kbps	44.8kbps
MCS-3	GMSK	A	14.8kbps	29.6kbps	59.2kbps
MCS-4	GMSK	C	17.6kbps	35.2kbps	70.4kbps
MCS-5	8-PSK	B	22.4kbps	44.8kbps	89.6kbps
MCS-6	8-PSK	A	29.6kbps	59.2kbps	118.4kbps
MCS-7	8-PSK	B	44.8kbps	89.6kbps	179.2kbps
MCS-8	8-PSK	A	54.4kbps	108.8kbps	217.6kbps
MCS-9	8-PSK	A	59.2kbps	118.4kbps	236.8kbps