

UC15 Mini PCIe

Hardware Design

UMTS/HSDPA Module Series

Rev. UC15_Mini_PcIe_Hardware_Design_V1.0

Date: 2014-04-24



Our aim is to provide customers with timely and comprehensive service. For any assistance, please contact our company headquarters:

Quectel Wireless Solutions Co., Ltd.

Office 501, Building 13, No.99, Tianzhou Road, Shanghai, China, 200233

Tel: +86 21 5108 6236

Mail: info@quectel.com

Or our local office, for more information, please visit:

<http://www.quectel.com/support/salesupport.aspx>

For technical support, to report documentation errors, please visit:

<http://www.quectel.com/support/techsupport.aspx>

GENERAL NOTES

QUECTEL OFFERS THIS INFORMATION AS A SERVICE TO ITS CUSTOMERS. THE INFORMATION PROVIDED IS BASED UPON CUSTOMERS' REQUIREMENTS. QUECTEL MAKES EVERY EFFORT TO ENSURE THE QUALITY OF THE INFORMATION IT MAKES AVAILABLE. QUECTEL DOES NOT MAKE ANY WARRANTY AS TO THE INFORMATION CONTAINED HEREIN, AND DOES NOT ACCEPT ANY LIABILITY FOR ANY INJURY, LOSS OR DAMAGE OF ANY KIND INCURRED BY USE OF OR RELIANCE UPON THE INFORMATION. THE INFORMATION SUPPLIED HEREIN IS SUBJECT TO CHANGE WITHOUT PRIOR NOTICE.

COPYRIGHT

THIS INFORMATION CONTAINED HERE IS PROPRIETARY TECHNICAL INFORMATION OF QUECTEL CO., LTD. TRANSMITTABLE, REPRODUCTION, DISSEMINATION AND EDITING OF THIS DOCUMENT AS WELL AS UTILIZATION OF THIS CONTENTS ARE FORBIDDEN WITHOUT PERMISSION. OFFENDERS WILL BE HELD LIABLE FOR PAYMENT OF DAMAGES. ALL RIGHTS ARE RESERVED IN THE EVENT OF A PATENT GRANT OR REGISTRATION OF A UTILITY MODEL OR DESIGN.

Copyright © Quectel Wireless Solutions Co., Ltd. 2014. All rights reserved.

About the Document

History

Revision	Date	Author	Description
1.0	2014-04-24	Mountain ZHOU	Initial

Quectel
Confidential

Contents

About the Document	2
Contents	3
Table Index	5
Figure Index	6
1 Introduction	7
1.1. Safety Information.....	7
2 Product Concept	9
2.1. General Description.....	9
2.2. Description of Product Version.....	9
2.3. Key Features.....	10
2.4. Functional Diagram.....	12
3 Application Interface	13
3.1. General Description.....	13
3.2. UC15 Mini PCIe Interface.....	13
3.2.1. Definition of Interface.....	13
3.2.2. Pin Assignment.....	16
3.3. Power Supply.....	17
3.4. UART Interface.....	17
3.5. USIM Card Interface.....	19
3.6. USB Interface.....	22
3.7. Audio Interface.....	23
3.7.1. Digital Audio Interface.....	23
3.7.2. Analog Audio Interface.....	25
3.8. Control Signals.....	28
3.8.1. W_DISABLE# Signal.....	28
3.8.2. PERST# Signal.....	29
3.8.3. LED_WWAN# Signal.....	29
3.9. Antenna Interface.....	30
4 Electrical and Radio Characteristics	32
4.1. General Description.....	32
4.2. Power Supply Requirements.....	32
4.3. IO Requirements.....	32
4.4. Current Consumption.....	33
4.5. RF Characteristics.....	34
4.6. ESD Characteristics.....	34
5 Mechanical Dimensions	36
5.1. General Description.....	36
5.2. Mechanical Dimensions of UC15 Mini PCIe.....	36
5.3. Standard Dimensions of Mini PCI Express.....	37

5.4. Packaging 38

6 Appendix Reference 39

Quectel
Confidential

Table Index

TABLE 1: PRODUCT VERSION OF UC15 MINI PCIE	9
TABLE 2: KEY FEATURES OF UC15 MINI PCIE	10
TABLE 3: DEFINITION OF IO PARAMETERS.....	13
TABLE 4: DESCRIPTION OF PIN	14
TABLE 5: VCC_3V3 AND GND PINS.....	17
TABLE 6: PIN DEFINITION OF THE UART INTERFACE	18
TABLE 7: PIN DEFINITION OF THE USIM CARD INTERFACE	19
TABLE 8: PIN DESCRIPTION OF AMPHENOL USIM CARD CONNECTOR	21
TABLE 9: USB PIN DESCRIPTION	22
TABLE 10: PIN DEFINITION OF PCM AND I2C INTERFACE.....	24
TABLE 11: PIN DEFINITION OF ANALOG AUDIO INTERFACE.....	25
TABLE 12: INPUT CHARACTERISTICS.....	26
TABLE 13: OUTPUT CHARACTERISTICS.....	26
TABLE 14: DESCRIPTION OF CONTROL SIGNAL PINS.....	28
TABLE 15: RADIO OPERATIONAL STATES	28
TABLE 16: INDICATION OF NETWORK STATUS.....	30
TABLE 17: ANTENNA REQUIREMENTS.....	31
TABLE 18: POWER SUPPLY REQUIREMENTS.....	32
TABLE 19: IO REQUIREMENTS.....	33
TABLE 20: CURRENT CONSUMPTION.....	33
TABLE 21: OUTPUT POWER OF CONDUCTED RF	34
TABLE 22: RECEIVING SENSITIVITY OF CONDUCTED RF.....	34
TABLE 23: ESD CHARACTERISTICS	35
TABLE 24: RELATED DOCUMENTS	39
TABLE 25: TERMS AND ABBREVIATIONS.....	39

Figure Index

FIGURE 1: FUNCTIONAL DIAGRAM	12
FIGURE 2: PIN ASSIGNMENT	16
FIGURE 3: REFERENCE DESIGN OF POWER SUPPLY	17
FIGURE 4: THE DCE-DTE CONNECTION OF UART INTERFACE	18
FIGURE 5: RS232 LEVEL MATCH CIRCUIT	19
FIGURE 6: REFERENCE CIRCUIT OF THE 6 PIN USIM CARD	20
FIGURE 7: AMPHENOL C707 10M006 512 2 USIM CARD CONNECTOR	21
FIGURE 8: REFERENCE CIRCUIT OF USB INTERFACE	22
FIGURE 9: SHORT SYNC MODE TIMING	23
FIGURE 10: LONG SYNC MODE TIMING	24
FIGURE 11: REFERENCE CIRCUIT OF PCM APPLICATION WITH AUDIO CODEC	25
FIGURE 12: MICROPHONE REFERENCE DESIGN	26
FIGURE 13: REFERENCE DESIGN OF RECEIVER	27
FIGURE 14: REFERENCE DESIGN WITH AN AMPLIFIER FOR SPEAKER	27
FIGURE 15: REFERENCE DESIGN OF EARPHONE	27
FIGURE 16: TIMING OF RESETTING MODULE	29
FIGURE 17: REFERENCE CIRCUIT OF LED_WWAN#	29
FIGURE 18: UC15 MINI PCIE ANTENNA INTERFACE	30
FIGURE 19: DIMENSIONS OF THE RF CONNECTOR (UNIT: MM)	30
FIGURE 20: MECHANICALS OF U.F.L-LP CONNECTORS	31
FIGURE 21: MECHANICAL DIMENSIONS OF UC15 MINI PCIE (UNIT: MM)	36
FIGURE 22: STANDARD DIMENSIONS OF MINI PCI EXPRESS (UNIT: MM)	37
FIGURE 23: DIMENSIONS OF THE MINI PCI EXPRESS CONNECTOR (UNIT: MM)	38

1 Introduction

This document defines UC15 Mini PCIe module and describes its hardware interfaces which are connected with your application and air interfaces.

This document can help you to quickly understand the interface specifications, electrical and mechanical details and related product information of the UC15 Mini PCIe module. Associated with application notes and user guide of UC15 Mini PCIe module, you can use the module to design and set up mobile applications easily.

1.1. Safety Information

The following safety precautions must be observed during all phases of the operation, such as usage, service or repair of any cellular terminal or mobile incorporating UC15 Mini PCIe module. Manufacturers of the cellular terminal should send the following safety information to users and operating personnel and to incorporate these guidelines into all manuals supplied with the product. If not so, Quectel does not take on any liability for customer failure to comply with these precautions.



Full attention must be given to driving at all times in order to reduce the risk of an accident. Using a mobile while driving (even with a handsfree kit) cause distraction and can lead to an accident. You must comply with laws and regulations restricting the use of wireless devices while driving.



Switch off the cellular terminal or mobile before boarding an aircraft. Make sure it switched off. The operation of wireless appliances in an aircraft is forbidden to prevent interference with communication systems. Consult the airline staff about the use of wireless devices on boarding the aircraft, if your device offers a Airplane Mode which must be enabled prior to boarding an aircraft.



Switch off your wireless device when in hospitals or clinics or other health care facilities. These requests are desinged to prevent possible interference with sentitive medical equipment.



Cellular terminals or mobiles operate over radio frequency signal and cellular network and cannot be guaranteed to connect in all conditions, for example no mobile fee or an invalid SIM card. While you are in this condition and need emergent help, please remember using emergency call. In order to make or receive call, the cellular terminal or mobile must be switched on and in a service area with adequate cellular signal strength.



Your cellular terminal or mobile contains a transmitter and receiver. When it is ON, it receives and transmits radio frequency energy. RF interference can occur if it is used close to TV set, radio, computer or other electric equipment.



In locations with potentially explosive atmospheres, obey all posted signs to turn off wireless devices such as your phone or other cellular terminals. Areas with potentially explosive atmospheres including fuelling areas, below decks on boats, fuel or chemical transfer or storage facilities, areas where the air contains chemicals or particles such as grain, dust or metal powders.

Quectel
Confidential

2 Product Concept

2.1. General Description

UC15 Mini PCIe module is a cost effective UMTS/HSDPA module featuring a maximum data rate of 3.6Mbps downlink and 384kbps uplink, according to PCI Express Mini Card 1.2 standard, supports embedded operating system such as WinCE, Linux and Android etc.

UC15 Mini PCIe module can be applied in the following fields:

- PDAs and Laptop Computer
- Remote Monitor System
- Vehicle System
- Wireless POS System
- Intelligent Meter Reading System
- Wireless Router and Switch
- Other Wireless Terminal Device

This chapter generally introduces the following aspects of UC15 Mini PCIe module:

- Product Version
- Key Features
- Functional Diagram

2.2. Description of Product Version

The following table shows the product version of UC15 Mini PCIe module.

Table 1: Product Version of UC15 Mini PCIe

Product Version	Description
Telematics	Support voice and data.
Data Only	Support data only.

2.3. Key Features

The following table describes the detailed features of UC15 Mini PCIe module.

Table 2: Key Features of UC15 Mini PCIe

Feature	Details
Function Interface	PCI Express Mini Card 1.2 Standard Interface
Power Supply	Supply voltage: 3.0~3.6V Typical supply voltage: 3.3V
Frequency Bands	GSM900/1800, UMTS900/2100
Transmission Data	HSDPA R5: Max 3.6Mbps (DL) UMTS R99: Max 384kbps (DL)/Max 384kbps (UL) EDGE: Max 236.8kbps (DL only) GPRS: Max 85.6kbps (DL)/Max 85.6kbps (UL) CSD: 64kbps
Transmitting Power	Class 4 (33dBm±2dB) for EGSM900 Class 1 (30dBm±2dB) for DCS1800 Class E2 (27dBm±3dB) for EGSM900 8-PSK Class E2 (26dBm+3/-4dB) for DCS1800 8-PSK Class 3 (24dBm+1/-3dB) for UMTS900/2100
HSDPA and WCDMA Features	HSDPA data rate is corresponded with 3GPP R5. 3.6Mbps on downlink. WCDMA data rate is corresponded with 3GPP R99/R4. 384kbps on downlink and 384kbps on uplink. Support both QPSK and 16-QAM modulation.
GSM/GPRS/EDGE Data Features	GPRS: Support GPRS multi-slot class 12 (10 by default). Coding scheme: CS-1, CS-2, CS-3 and CS-4. Maximum of four Rx time slots per frame. EDGE: Support EDGE multi-slot class 12 (12 by default). Support GMSK and 8-PSK for different MCS (Modulation and Coding Scheme). Downlink coding schemes: CS 1-4 and MCS 1-9. CSD: CSD transmission rates: 64kbps non-transparent. Support Unstructured Supplementary Services Data (USSD).
Internet Protocol Features	Support TCP/IP/PPP/UDP protocols. Support the protocols PAP (Password Authentication Protocol) and CHAP (Challenge Handshake Authentication Protocol) usually used for PPP connections.
SMS	Text and PDU mode Point to point MO and MT

	SMS cell broadcast SMS storage: ME by default
USIM Interface	Support USIM/SIM card: 1.8V, 3.0V
UART Interface	Support seven lines on UART interface. Support RTS and CTS hardware flow control. Baud rate can reach up to 230400 bps, 115200 bps by default. Used for AT command and data transmission. Support multiplexing function.
Analog Audio Interface*	Support one differential input and one differential output channel. GSM: HR/FR/EFR/AMR/AMR-WB WCDMA: AMR/AMR-WB Echo cancellation and noise suppression
PCM Digital Audio Interface*	Support 16-bit linear data formats. Support long frame sync and short frame sync. Support master and slave mode, but must be the master in long frame sync.
USB Interface	Compliant with USB 2.0 specification (slave only), the data transfer rate can reach up to 480 Mbps. Used for AT command communication, data transmission, software debug and firmware upgrade. USB Driver: Support Windows XP, Windows Vista, Windows 7, Windows 8, WinCE 5.0/6.0, Windows Mobile 6.1/6.5, Linux 2.6 or later, Android 2.3 or later.
Antenna Interface	One GSM/UMTS antenna connector.
AT Commands	Compliant with 3GPP TS 27.007, 27.005 and Quectel enhanced AT commands.
Physical Characteristics	Size: 51.0 × 30.0 × 4.9mm Weight: Approx. 9.3g
Temperature Range	Normal operation: -30°C ~ +70°C Restricted operation: -40°C ~ -30°C and +70°C ~ +80°C [▲] Storage temperature: -45°C ~ +90°C
Firmware Upgrade	USB interface
RoHS	All hardware components are fully compliant with EU RoHS directive.

NOTES

- “▲” means when the module works within this temperature range, RF performance might degrade. For example, the frequency error or the phase error may increase.
- “*” means these functions are only supported in Telematics version. Meanwhile, PCM function is still under development.

2.4. Functional Diagram

The following figure shows a block diagram of UC15 Mini PCIe and illustrates the major functional parts:

- USIM/SIM card interface (1.8V/3.0V)
- USB 2.0 interface
- UART interface (seven lines)
- Audio interface
- I2C interface
- Support LED status indication
- Support disabling wireless communication function
- Support hardware reset function
- Support GSM/UMTS antenna interface

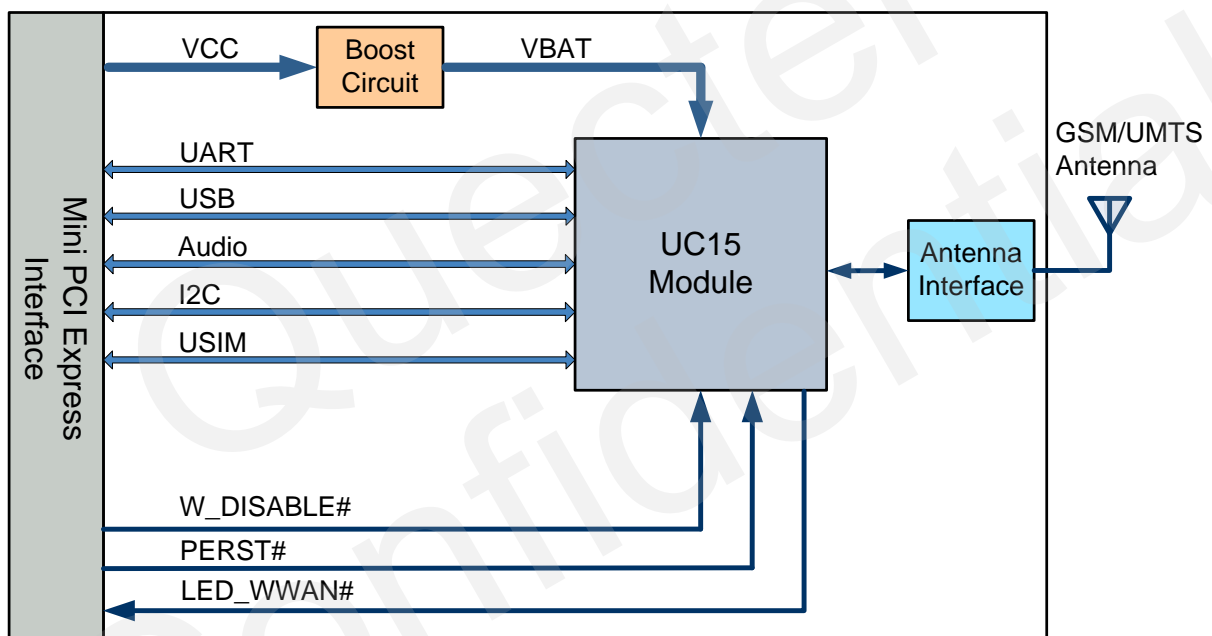

Figure 1: Functional Diagram

3 Application Interface

3.1. General Description

The physical connections and signal levels of UC15 Mini PCIe comply with PCI Express Mini CEM specifications. This chapter mainly describes the definition of following interfaces and applications of UC15 Mini PCIe.

- Power supply
- UART interface
- USIM interface
- USB interface
- Audio interface
- Antenna interface
- Control signals (W_DISABLE#, PERST# and LED_WWAN#)

3.2. UC15 Mini PCIe Interface

3.2.1. Definition of Interface

The following tables show the pin assignments of UC15 Mini PCIe on the 52-pin application.

Table 3: Definition of IO Parameters

Type	Description
AI	Analog input
AO	Analog output
DI	Digital input
DO	Digital output
IO	Bidirectional input/output
OC	Open collector

PI Power input

PO Power output

Table 4: Description of Pin

Pin No.	Mini PCI Express Standard Name	UC15 Mini PCIe Pin Name	I/O	Description	Comment
1	WAKE#	MICP*	AI	Audio positive input	
2	3.3Vaux	VCC_3V3	PI	3.3V DC supply	
3	COEX1	MICN*	AI	Audio negative input	
4	GND	GND	—	Mini card ground	
5	COEX2	SPKP*	AO	Audio positive output	
6	1.5V	NC	—	—	
7	CLKREQ#	SPKN*	AO	Audio negative output	
8	UIM_PWR	USIM_VDD	PO	Power source for the USIM card	
9	GND	GND	—	Mini card ground	
10	UIM_DATA	USIM_DATA	IO	USIM data signal	
11	REFCLK-	UART_RX	DI	UART receives data	Connect to DTE's TX.
12	UIM_CLK	USIM_CLK	DO	USIM clock signal	
13	REFCLK+	UART_TX	DO	UART transmits data	Connect to DTE's RX.
14	UIM_RESET	USIM_RST	DO	USIM reset signal	
15	GND	GND	—	Mini card ground	
16	UIM_VPP	RESERVED	—	Reserved	
17	RESERVED	UART_RI	DO	UART ring indicator	
18	GND	GND	—	Mini card ground	
19	RESERVED	RESERVED	—	Reserved	
20	W_DISABLE#	W_DISABLE#	DI	Disable wireless communications	Active low.
21	GND	GND	—	Mini card ground	

22	PERST#	PERST#	DI	Functional reset to the card	Active low pulse.
23	PERn0	UART_CTS	DI	UART clear to send	Connect to DTE's RTS.
24	3.3Vaux	RESERVED	—	Reserved	
25	PERp0	UART_RTS	DO	UART request to send	Connect to DTE's CTS.
26	GND	GND	—	Mini card ground	
27	GND	GND	—	Mini card ground	
28	1.5V	NC	—	—	
29	GND	GND	—	Mini card ground	
30	SMB_CLK	I2C_SCL	DO	I2C clock signal	
31	PETn0	UART_DTR	DI	UART data terminal ready	
32	SMB_DATA	I2C_SDA	IO	I2C data signal	
33	PETp0	UART_DCD	DO	UART data carrier detection	
34	GND	GND	—	Mini card ground	
35	GND	GND	—	Mini card ground	
36	USB_D-	USB_DM	IO	USB differential data (-)	
37	GND	GND	—	Mini card ground	
38	USB_D+	USB_DP	IO	USB differential data (+)	
39	3.3Vaux	VCC_3V3	PI	3.3V DC supply	
40	GND	GND	—	Mini Card ground	
41	3.3Vaux	VCC_3V3	PI	3.3V DC supply	
42	LED_WWAN#	LED_WWAN#	OC	Active-low LED signal for indicating the state of the card	
43	GND	GND	—	Mini card ground	
44	LED_WLAN#	RESERVED	—	Reserved	
45	RESERVED	PCM_CLK*	IO	PCM clock signal	
46	LED_WPAN#	RESERVED	—	Reserved	
47	RESERVED	PCM_DOUT*	DO	PCM data output	

48	1.5V	NC	—	—
49	RESERVED	PCM_DIN*	DI	PCM data input
50	GND	GND	—	Mini card ground
51	RESERVED	PCM_SYNC*	IO	PCM frame sync signal
52	3.3Vaux	VCC_3V3	PI	3.3V DC supply

NOTES

1. PCM and analog audio interface are only supported in Telematics version.
2. Keep all NC, reserved and unused pins unconnected.

3.2.2. Pin Assignment

The following figure shows the pin assignment of UC15 Mini PCIe module. The top side contains UC15 module and antenna connectors.

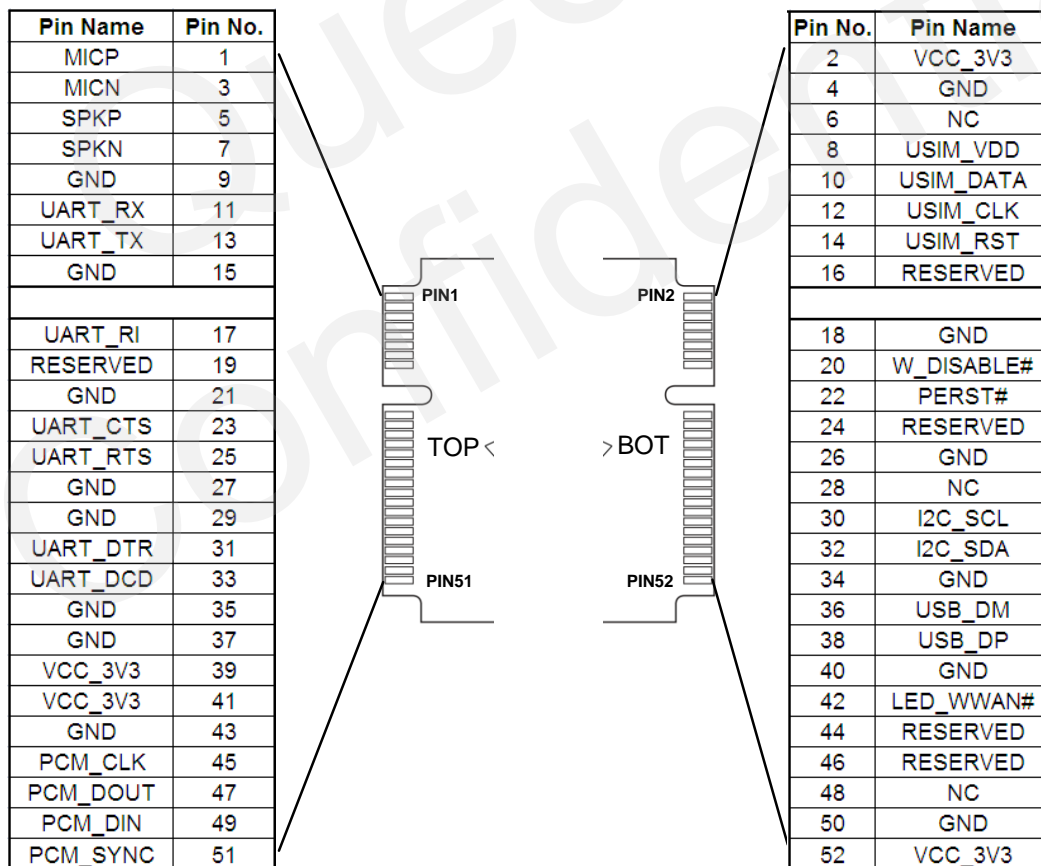

Figure 2: Pin Assignment

3.3. Power Supply

The following table shows the VCC_3V3 pins and ground pins.

Table 5: VCC_3V3 and GND Pins

Pin No.	Pin Name	I/O	Description
2, 39, 41, 52	VCC_3V3	PI	3.3V DC supply.
4, 9, 15, 18, 21, 26, 27, 29, 34, 35, 37, 40, 43, 50	GND	—	Mini card ground.

The typical supply voltage of UC15 Mini PCIe is 3.3V. In the 2G networks, the input peak current may reach to 2.7A during the transmitting time, therefore the power supply must be able to provide enough current, and a bypass capacitor of no less than 100µF with low ESR should be used to prevent the voltage from dropping.

The following figure shows a reference design of power supply. The precision of resistor R2 and R3 is 1%, and the capacitor C3 needs a low ESR.

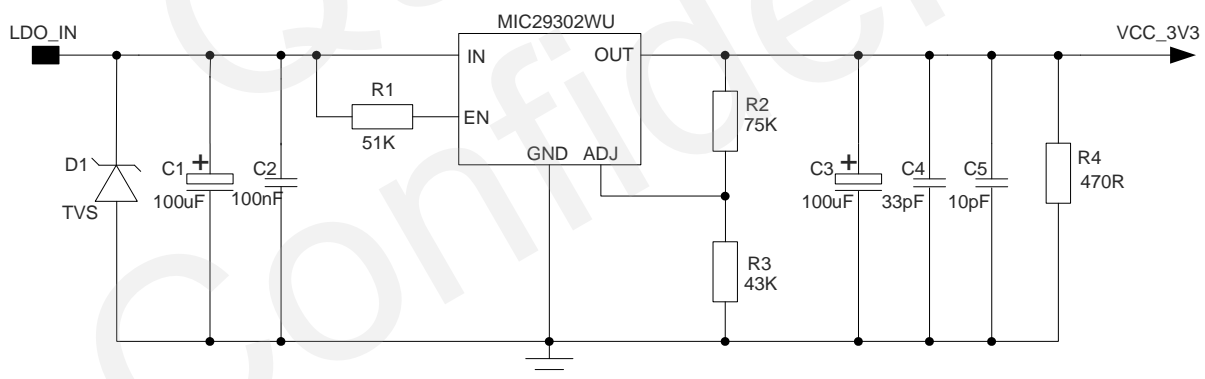

Figure 3: Reference Design of Power Supply

3.4. UART Interface

The following table shows the pin definition of the UART interface.

Table 6: Pin Definition of the UART Interface

Pin No.	Pin Name	I/O	Description	Power Domain
11	UART_RX	DI	UART receives data	3.3V
13	UART_TX	DO	UART transmits data	3.3V
17	UART_RI	DO	UART ring indicator	3.3V
23	UART_CTS	DI	UART clear to send	3.3V
25	UART_RTS	DO	UART request to send	3.3V
31	UART_DTR	DI	UART data terminal ready	3.3V
33	UART_DCD	DO	UART data carrier detection	3.3V

The UART interface supports 300, 600, 1200, 4800, 9600, 19200, 38400, 57600, 115200 and 230400bps baud rate. The default is 115200bps. Autobauding is not supported. This interface can be used for data transmission and AT communication.

UC15 Mini PCIe is designed as the DCE, and the DCE-DTE connection of UART interface is shown as below.

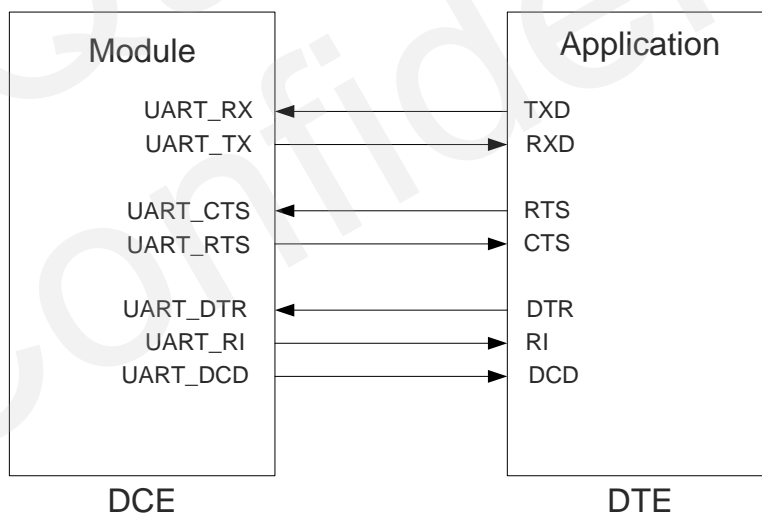

Figure 4: The DCE-DTE Connection of UART Interface

The following figure is an example of connection between UC15 Mini PCIe and PC. Since the UART interface does not support the RS-232 level, RS-232 level translator IC must be inserted between module and PC. The following figure shows the reference design of RS232 level match circuit.

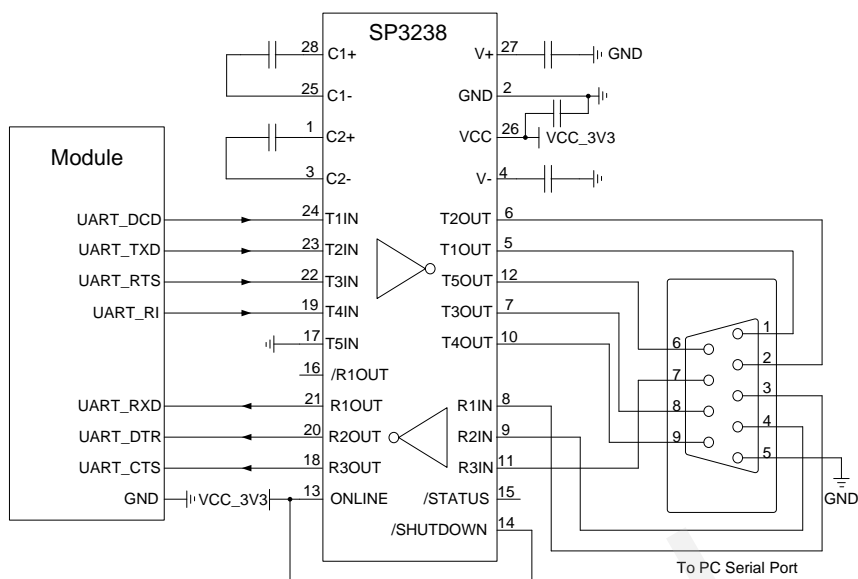

Figure 5: RS232 Level Match Circuit

NOTES

1. The hardware flow control is disabled by default. AT command **AT+IFC=2,2** is used to enable the hardware flow control. AT command **AT+IFC=0,0** is used to disable the hardware flow control. For more details, please refer to **document [2]**.
2. AT command **AT+IPR** is used to set the baud rate of the UART. Please refer to **document [2]** for details.
3. UART_DTR supports sleep control function. Driving it to low level will wake up the module, and it can be disabled by command **AT+QCFG="pwrsavedtr",0**. Meanwhile, the rising edge on UART_DTR will let the module exit from data mode. Refer to **document [2]** of command **AT&D** for details.
4. UART_DCD is used as data transferring indication. You can refer to **document [2]** for details of **AT&C** command. This pin can also be used as AP_READY function, which can detect the host sleep state to avoid the URC loss during the time when the host is waking up from the sleep state. For details about AP_READY, please contact Quectel technical support.

3.5. USIM Card Interface

The following table shows the pin definition of the USIM card interface.

Table 7: Pin Definition of the USIM Card Interface

Pin No.	Pin Name	I/O	Description	Power Domain
8	USIM_VDD	PO	Power for the USIM/SIM card.	1.8V/3.0V

10	USIM_DATA	IO	USIM/SIM data signal.	1.8V/3.0V
12	USIM_CLK	DO	USIM/SIM clock signal.	1.8V/3.0V
14	USIM_RST	DO	USIM/SIM reset signal.	1.8V/3.0V

UC15 Mini PCIe supports 1.8V and 3.0V USIM cards. The following figure shows the reference design of the 6-pin USIM card.

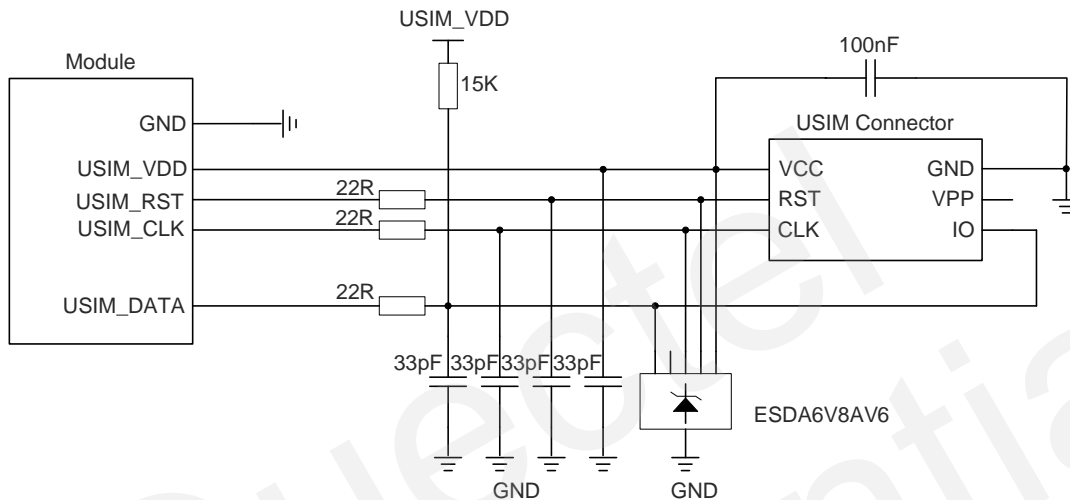

Figure 6: Reference Circuit of the 6 Pin USIM Card

In order to enhance the reliability and availability of the USIM card in your application, please follow the criteria below in the USIM circuit design:

- Keep layout of USIM card as close to the module as possible. Assure the length of the trace as less than 200mm as possible.
- Keep USIM card signal away from RF and power supply alignment.
- The decouple capacitor of USIM_VDD should be less than 1uF and must be close to USIM connector.
- To avoid cross-talk between USIM_DATA and USIM_CLK, keep them away from each other and shield them with surrounding ground.
- In order to offer good ESD protection, it is recommended to add TVS such as WILL (<http://www.willsemi.com>) ESDA6V8AV6. The 22Ω resistors should be added in series between the module and USIM card so as to suppress the EMI spurious transmission and enhance the ESD protection. The 33pF capacitors are used for filtering interference of EGSM900. Please note that the USIM peripheral circuit should be close to the USIM connector.
- The pull-up resistor on USIM_DATA line can improve anti-jamming capability when long layout trace and sensitive occasion are applied.

For 6-pin USIM connector, it is recommended to use Amphenol C707 10M006 512 2. Please visit <http://www.amphenol.com> for more information.

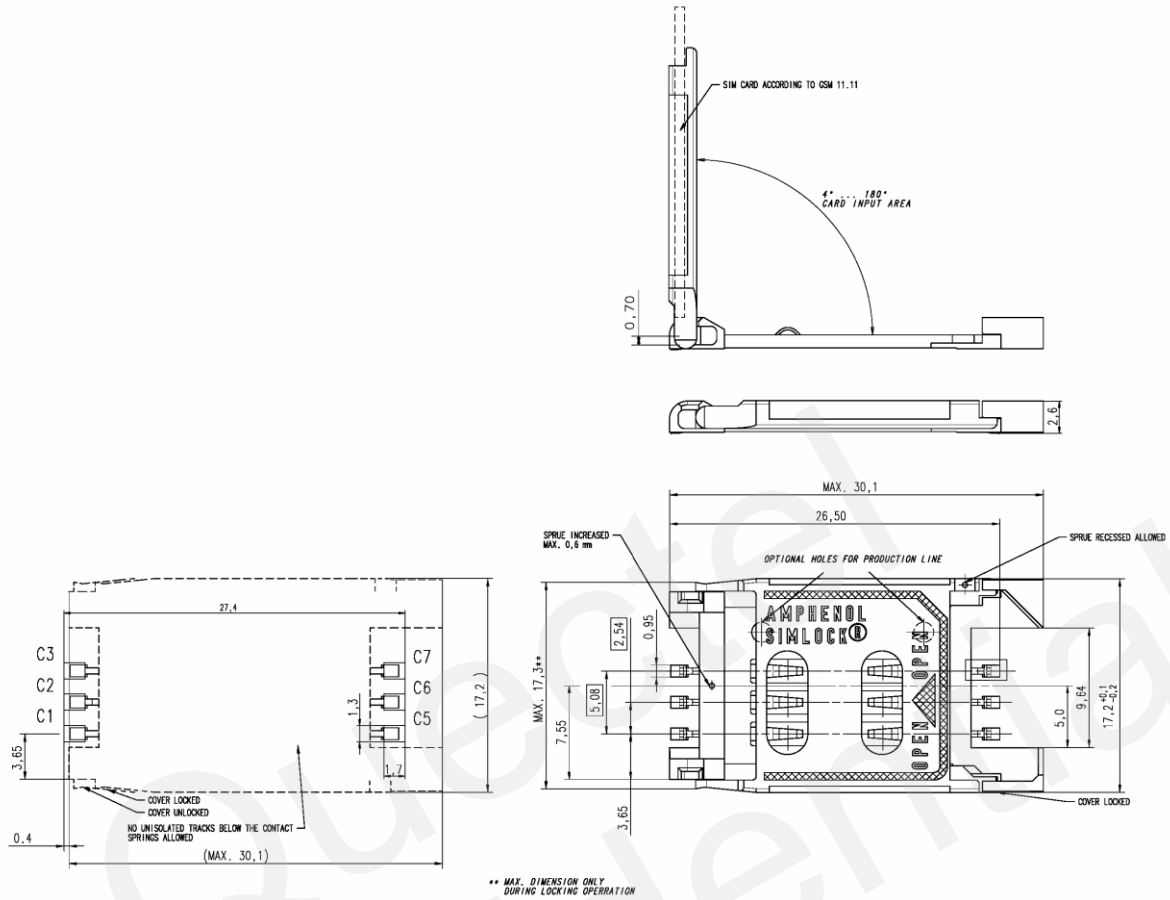

Figure 7: Amphenol C707 10M006 512 2 USIM Card Connector

Table 8: Pin Description of Amphenol USIM Card Connector

Name	Pin	Function
VDD	C1	USIM card power supply
RST	C2	USIM card reset
CLK	C3	USIM card clock
GND	C5	Ground
VPP	C6	Not connected
DATA I/O	C7	USIM card data

3.6. USB Interface

The following table shows the pin definition of USB interface.

Table 9: USB Pin Description

Pin No.	Pin Name	I/O	Description	Comment
36	USB_DM	IO	USB differential data (-).	Require differential impedance of 90Ω.
38	USB_DP	IO	USB differential data (+).	Require differential impedance of 90Ω.

UC15 Mini PCIe is compliant with USB 2.0 specification. It can only be used as a slave device. Meanwhile, it supports high speed (480 Mbps), full speed (12 Mbps) and low speed (1.5 Mbps) mode. The USB interface can be used for AT command, data transmission, software debug and firmware upgrade. The following figure shows the reference circuit of USB interface.

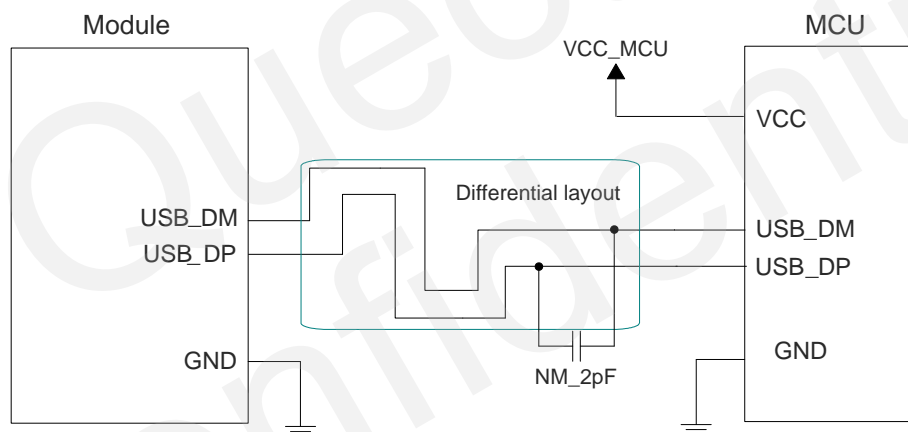

Figure 8: Reference Circuit of USB Interface

To ensure the USB interface design corresponds with the USB 2.0 specification, please comply with the following principles.

- It is important to route the USB signal traces as differential pairs with total grounding. The impedance of USB differential trace is 90ohm.
- Do not route signal traces under crystals, oscillators, magnetic devices and RF signal traces. It is important to route the USB differential traces in inner-layer with ground shielding, and not only upper and lower layer but also right and left side should be shielded.
- If you use the USB connector, you should install the ESD components as close to the USB connector as possible. Pay attention to the influence of junction capacitance of ESD component on USB data lines. Typically, the capacitance value should be less than 2pF (e.g.ESD9L5.0ST5G).

NOTES

There are three preconditions when enabling UC15 Mini PCIe to enter the sleep mode:

1. Execute AT command **AT+QSCLK=1** to enable the sleep mode. Refer to **document [2]**.
2. UART_DTR pin should be kept in high level (pull-up internally).
3. USB interface on Mini PCIe must be connected with your USB interface, and guarantee USB devices are in the suspended state.

3.7. Audio Interface

3.7.1. Digital Audio Interface

UC15 Mini PCIe Telematics version provides one Pulse Code Modulation (PCM) digital audio interface, which supports the following modes.

- Short sync mode (works as both master and slave)
- Long sync mode (works as master only)

When module works in the short sync mode, PCM_CLK=2048kHz and PCM_SYNC=8kHz. The data is sampled on the falling edge of the PCM_CLK and transmitted on the rising edge, and the PCM_SYNC falling edge represents the MSB.

When module works in the long sync mode, PCM_CLK=128kHz and PCM_SYNC=8kHz. The data is sampled on the falling edge of the PCM_CLK and transmitted on the rising edge, and the PCM_SYNC rising edge represents the MSB.

The following figures show timing relationship of these two modes.

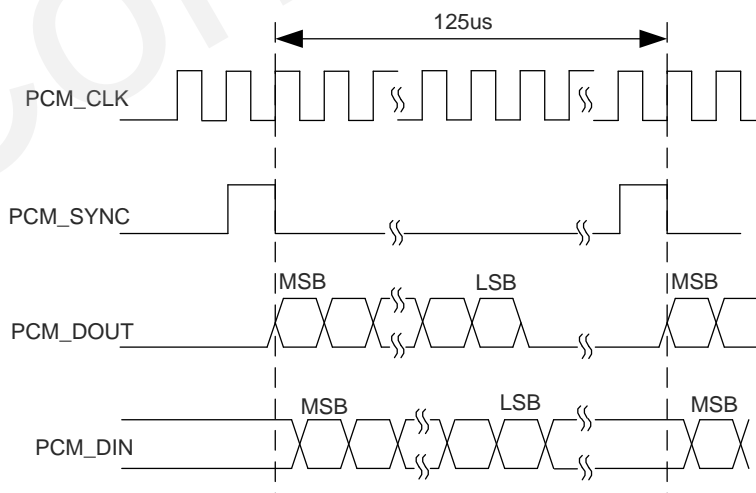

Figure 9: Short Sync Mode Timing

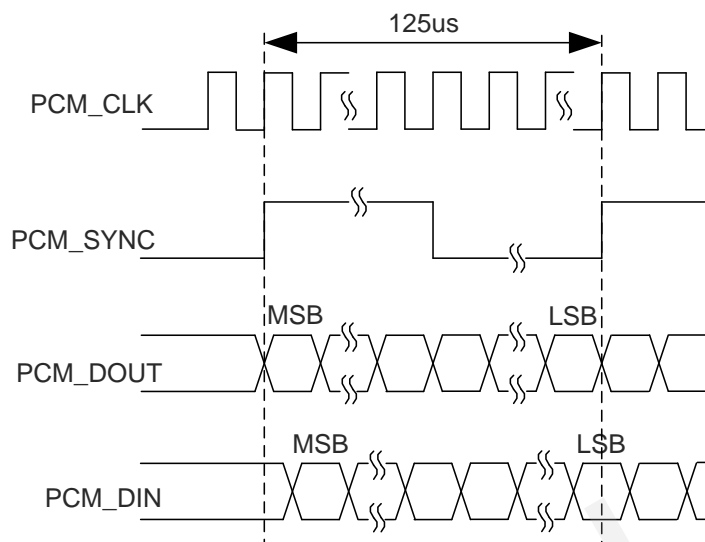

Figure 10: Long Sync Mode Timing

I2C interface can be used to work with PCM interface for the audio codec design. The following table shows the pin definition of PCM and I2C interfaces.

Table 10: Pin Definition of PCM and I2C Interface

Pin No.	Pin Name	I/O	Description	Power Domain
30	I2C_SCL	DO	I2C clock signal	Require external pull-up to 2.6V.
32	I2C_SDA	IO	I2C data signal	Require external pull-up to 2.6V.
45	PCM_CLK	IO	PCM clock signal	2.6V
47	PCM_DOUT	DO	PCM data output	2.6V
49	PCM_DIN	DI	PCM data input	2.6V
51	PCM_SYNC	IO	PCM frame sync signal	2.6V

Module firmware has integrated the configuration on NAU8814 application with I2C interface, and works in short sync mode by default. You can enable this configuration with command **AT+QDAI=2**, and **AT+QAUDPATH=2** will configure the audio channel to PCM interface, **AT+QAUDPATH=0** configures the audio channel to analog audio interface. Refer to **document [2]** for details.

The following figure shows the reference design of PCM interface with external codec IC.

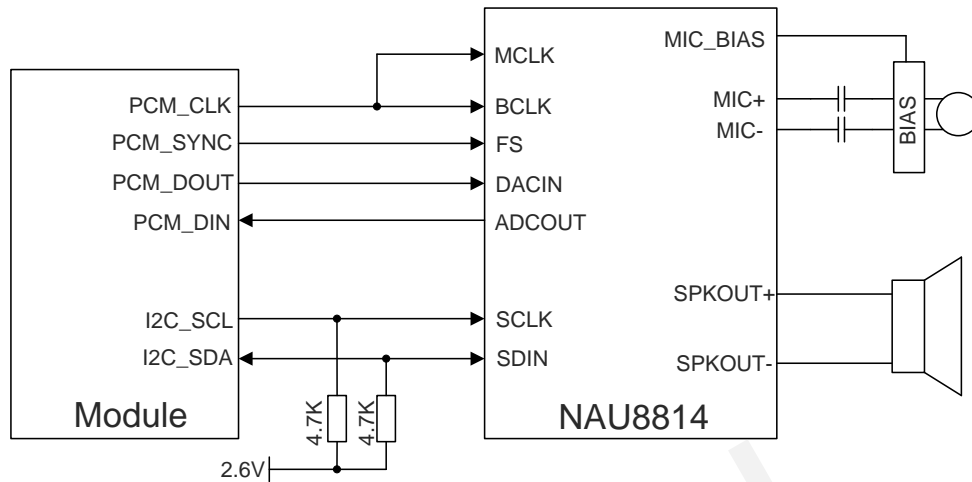

Figure 11: Reference Circuit of PCM Application with Audio Codec

NOTE

It is recommended to reserve RC (R=22Ω, C=22pF) circuit on the PCM lines, especially for PCM_CLK.

3.7.2. Analog Audio Interface

UC15 Mini PCIe Telematics version supports one differential input and output analog audio interface, and this interface works as the default audio channel. The following tables show the pin definition and characteristics of analog audio interface.

Table 11: Pin Definition of Analog Audio Interface

Pin No.	Pin Name	I/O	Description
1	MICP	AI	Audio positive input.
3	MICN	AI	Audio negative input.
5	SPKP	AO	Audio positive output.
7	SPKN	AO	Audio negative output.

Table 12: Input Characteristics

Parameter	Min.	Typ.	Max.	Unit
Working Voltage	1.65	1.8	1.95	V
Working Current	20		1000	uA

Table 13: Output Characteristics

Parameter	Min.	Typ.	Max.	Unit
Supply Voltage	2.0	2.1	2.2	V
Load Resistance	25.6	32		ohm
Output Power		50		mW

The following parts show the reference design of audio applications.

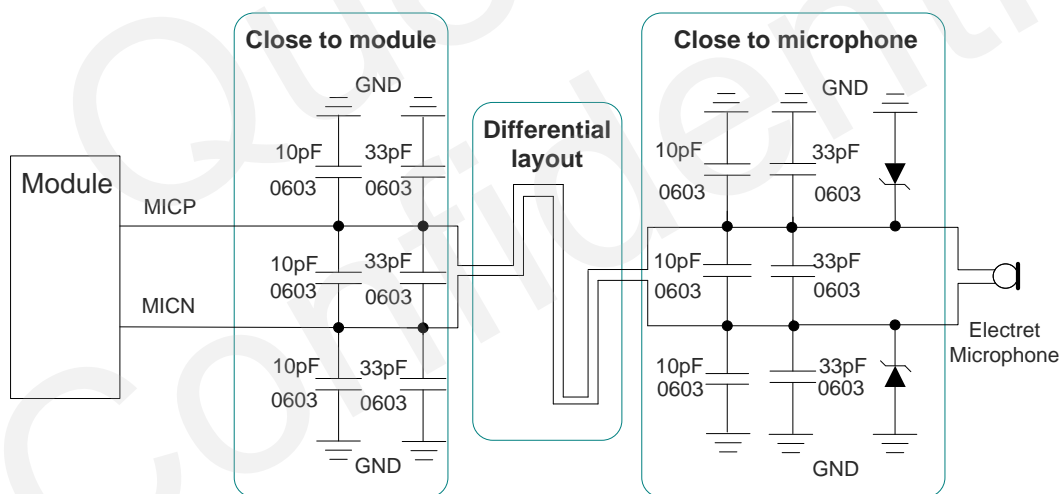

Figure 12: Microphone Reference Design

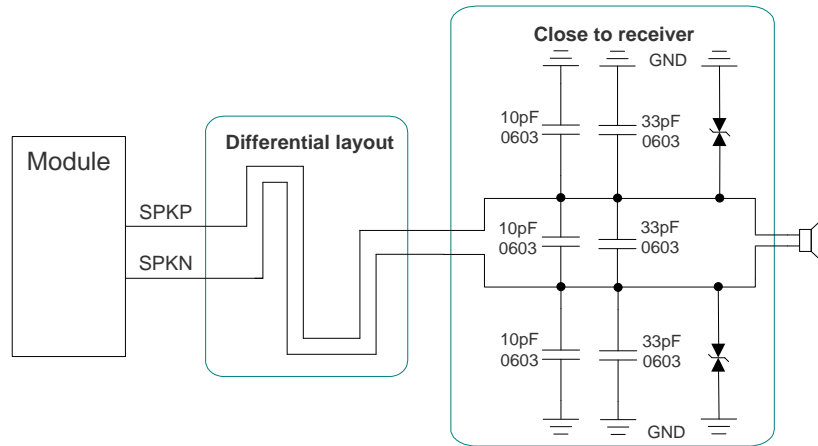

Figure 13: Reference Design of Receiver

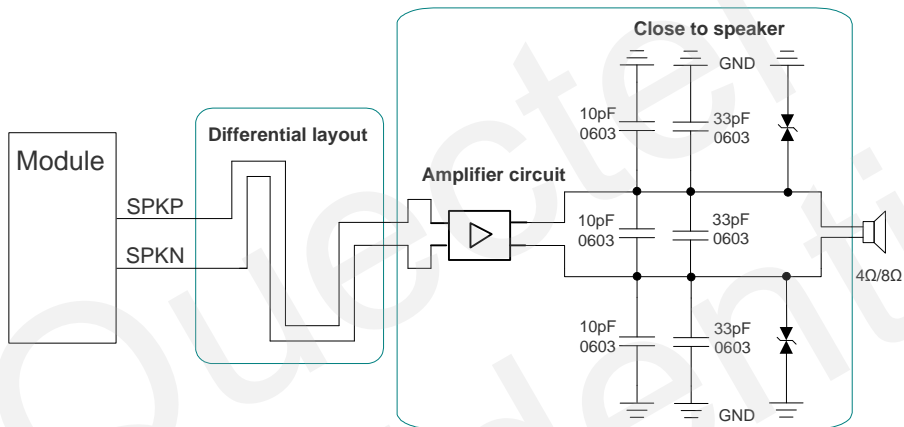

Figure 14: Reference Design with an Amplifier for Speaker

Texas Instruments TPA6205A1 is recommended for a suitable differential audio amplifier.

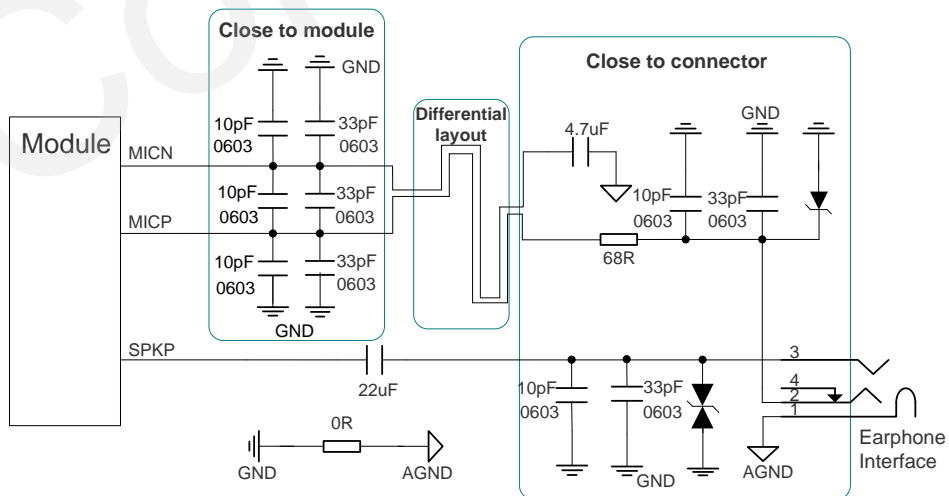

Figure 15: Reference Design of Earphone

You can use **AT+QMIC** to adjust the input gain level of microphone, use **AT+CLVL** to adjust the output gain level of receiver and speaker. **AT+QSIDET** is to set the side-tone gain level. For more details, please refer to **document [2]**.

The 33pF capacitors and 10pF capacitors are applied for filtering out 900MHz and 1800MHz RF interference. However, the self-resonant frequency point of capacitor largely depends on the material and production technique. Therefore, you should depend on the capacitor vendor to choose the most suitable capacitor for filtering out EGSM900 and DCS1800 separately.

In order to decrease radio or other signal interference, RF antenna should be kept away from audio interface and audio alignment. Power alignment and audio alignment should not be parallel, and power alignment should be far away from audio alignment. The differential audio traces should be placed according to the differential signal layout rules.

3.8. Control Signals

The following table shows the pin definition of control signals.

Table 14: Description of Control Signal Pins

Pin No.	Pin Name	I/O	Power Domain	Description
20	W_DISABLE#	DI	3.3V	Disable wireless communications. Active low.
22	PERST#	DI	3.3V	Functional reset to the card. Active low pulse.
42	LED_WWAN#	OC	—	Active-low LED signal for indicating the state of the card.

3.8.1. W_DISABLE# Signal

UC15 Mini PCIe provides W_DISABLE# signal to disable wireless communications through hardware operation. The following table shows the radio operational states of module. Please refer to **document [2]** for related AT commands.

Table 15: Radio Operational States

W_DISABLE#	AT Commands	Radio Operation
High Level	AT+CFUN=1	Enabled

High Level	AT+CFUN=0 AT+CFUN=4	Disabled
Low Level	AT+CFUN=0 AT+CFUN=1 AT+CFUN=4	Disabled

3.8.2. PERST# Signal

The PERST# signal can be used to force a hardware reset on the card. You can reset the module by driving the PERST# to a low level voltage for 0.05~0.2s and then release it. The reset scenario is illustrated in the following figure.

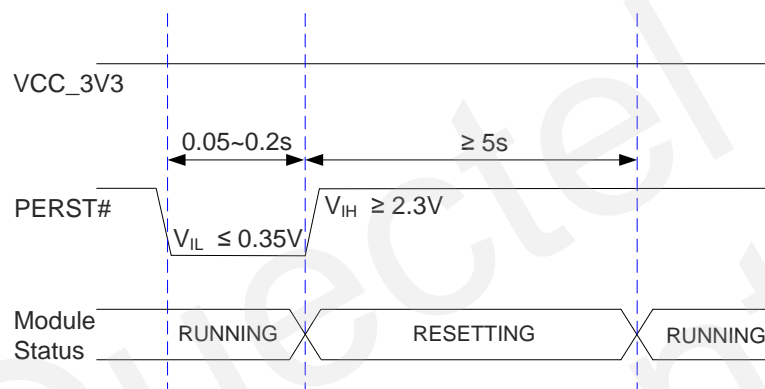

Figure 16: Timing of Resetting Module

3.8.3. LED_WWAN# Signal

The LED_WWAN# signal of UC15 Mini PCIe is used to indicate the network status of the module, which can absorb the current up to 40mA. According to the following circuit, in order to reduce the current of the LED, a resistor must be placed in series with the LED. The LED is emitting light when the LED_WWAN# output signal is active low.

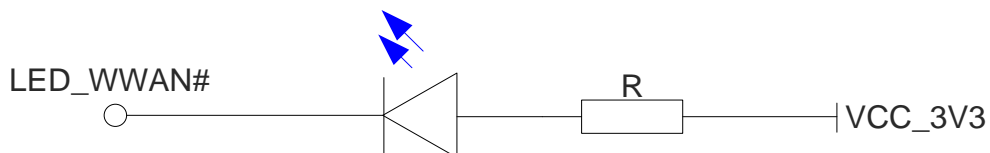

Figure 17: Reference Circuit of LED_WWAN#

The following table shows the indications of network status of the LED_WWAN# signal.

Table 16: Indication of Network Status

LED_WWAN#	Description
Low Level (Light on)	Registered network.
High-impedance (Light off)	<ul style="list-style-type: none"> No network coverage or not registered. W_DISABLE# signal is in low level. AT+CFUN=0 or AT+CFUN=4. Module gets into sleep mode.

3.9. Antenna Interface

The following figures show the location of antenna interface and describe the overall size of RF connector.



Figure 18: UC15 Mini PCIe Antenna Interface

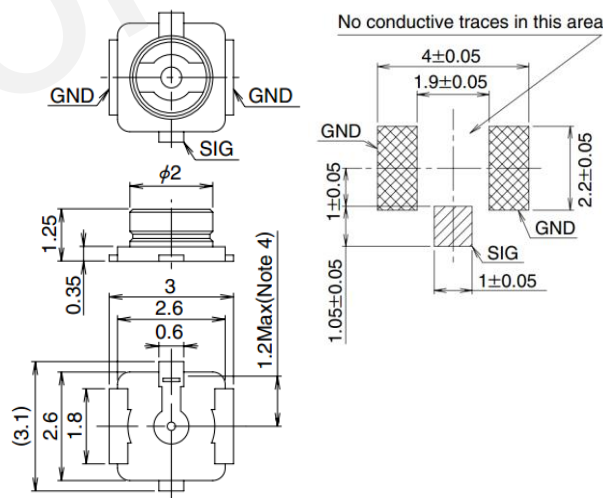

Figure 19: Dimensions of the RF Connector (Unit: mm)

You can use U.FL-LP serial connector listed in the following figure to match the ECT818000117. For more details, please visit <http://www.hirose.com>.

	U.FL-LP-040	U.FL-LP-066	U.FL-LP(V)-040	U.FL-LP-062	U.FL-LP-088
Part No.					
Mated Height	2.5mm Max. (2.4mm Nom.)	2.5mm Max. (2.4mm Nom.)	2.0mm Max. (1.9mm Nom.)	2.4mm Max. (2.3mm Nom.)	2.4mm Max. (2.3mm Nom.)
Applicable cable	Dia. 0.81mm Coaxial cable	Dia. 1.13mm and Dia. 1.32mm Coaxial cable	Dia. 0.81mm Coaxial cable	Dia. 1mm Coaxial cable	Dia. 1.37mm Coaxial cable
Weight (mg)	53.7	59.1	34.8	45.5	71.7
RoHS	YES				

Figure 20: Mechanicals of UF.L-LP Connectors

The following table shows the requirements on GSM/UMTS antenna.

Table 17: Antenna Requirements

Type	Requirements
EGSM900/UMTS900	Cable insertion loss < 0.5dB.
DCS1800/UMTS2100	Cable insertion loss < 0.9dB.

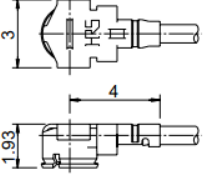
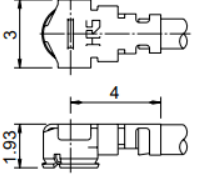
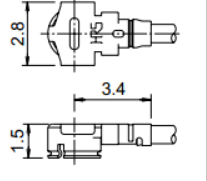
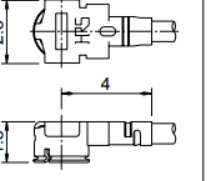
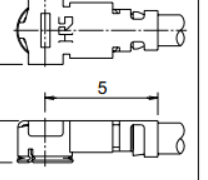
4 Electrical and Radio Characteristics

4.1. General Description

This chapter mainly describes the following electrical and radio characteristics of UC15 Mini PCIe:

- Power supply requirements
- IO requirements
- Current consumption
- RF characteristics
- ESD characteristics

4.2. Power Supply Requirements

The input voltage of UC15 Mini PCIe is $3.3V \pm 9\%$, as specified by PCI Express Mini CEM Specifications 1.2. The following table shows the power supply requirements of UC15 Mini PCIe.

Table 18: Power Supply Requirements

Parameter	Description	Min.	Typ.	Max.	Unit
VCC_3V3	Power supply	3.0	3.3	3.6	V

4.3. IO Requirements

The following table shows the IO requirements of UC15 Mini PCIe.

Table 19: IO Requirements

Parameter	Description	Min.	Max.	Unit
V _{IH}	Input high voltage	0.7*VDDIO	VDDIO+0.3	V
V _{IL}	Input low voltage	-0.3	0.2*VDDIO	V
V _{OH}	Output high voltage	VDDIO-0.5	VDDIO	V
V _{OL}	Output low voltage	0	0.4	V

NOTES

1. VDDIO=2.6V for PCM interface, and 3.3V for other digital interfaces.
2. The maximum value of V_{IL} for PERST# signal is 0.35V.

4.4. Current Consumption

The current consumptions of UC15 Mini PCIe in different scenarios are respectively shown below.

Table 20: Current Consumption

Description	Conditions	Typ.	Unit
Sleep	GSM (USB disconnected) @DRX=2	5.5	mA
	GSM (USB disconnected) @DRX=9	3.5	
	UMTS (USB disconnected) @DRX=6	5.8	
	UMTS (USB disconnected) @DRX=9	3.3	
Idle	GSM(USB connected) @DRX=2	80	mA
	GSM(USB disconnected) @DRX=2	50	
	UMTS(USB connected) @DRX=6	80	
	UMTS(USB disconnected) @DRX=6	45	
GSM Voice Call	EGSM900 @PCL5	320	mA
	DCS1800 @PCL0	262	
UMTS Voice Call	UMTS2100 @max power	596	mA
	UMTS900 @max power	596	
GPRS Data Transfer	GPRS900 (1UL/1DL) @PCL5	290	mA
	GPRS900 (2UL/3DL) @PCL5	401	
	DCS1800 (1UL/1DL) @PCL0	241	
	DCS1800 (2UL/3DL) @PCL0	333	

UMTS Data Transfer	UMTS2100 (HSDPA) @max power	516	mA
	UMTS900 (HSDPA) @max power	516	

4.5. RF Characteristics

The following tables show output power and receiving sensitivity of conducted RF of UC15 Mini PCIe module.

Table 21: Output Power of Conducted RF

Frequency	Max.	Min.
EGSM900	33dBm±2dB	5dBm±5dB
DCS1800	30dBm±2dB	0dBm±5dB
EGSM900 (8-PSK)	27dBm±3dB	5dBm±5dB
DCS1800 (8-PSK)	26dBm+3/-4dB	0dBm±5dB
UMTS2100	24dBm+1/-3dB	-56dBm±5dB
UMTS900	24dBm+1/-3dB	-56dBm±5dB

Table 22: Receiving Sensitivity of Conducted RF

Frequency	Receive Sensitivity (Typ.)
EGSM900	-108.5dBm
DCS1800	-108.5dBm
UMTS2100	-110dBm
UMTS900	-110dBm

4.6. ESD Characteristics

The following table shows characteristics of UC15 Mini PCIe ESD.

Table 23: ESD Characteristics

Parameter	Contact Discharge	Air Discharge	Unit
Power Supply and GND	±5	±10	kV
Antenna Interface	±4	±8	kV
USB Interface	±4	±8	kV
USIM Interface	±4	±8	kV
Others	±0.5	±1	kV

Quectel
Confidential

5 Mechanical Dimensions

5.1. General Description

This chapter mainly describes the following dimensions of UC15 Mini PCIe:

- Mechanical Dimensions of UC15 Mini PCIe
- Standard Dimensions of Mini PCI Express
- Packaging

5.2. Mechanical Dimensions of UC15 Mini PCIe

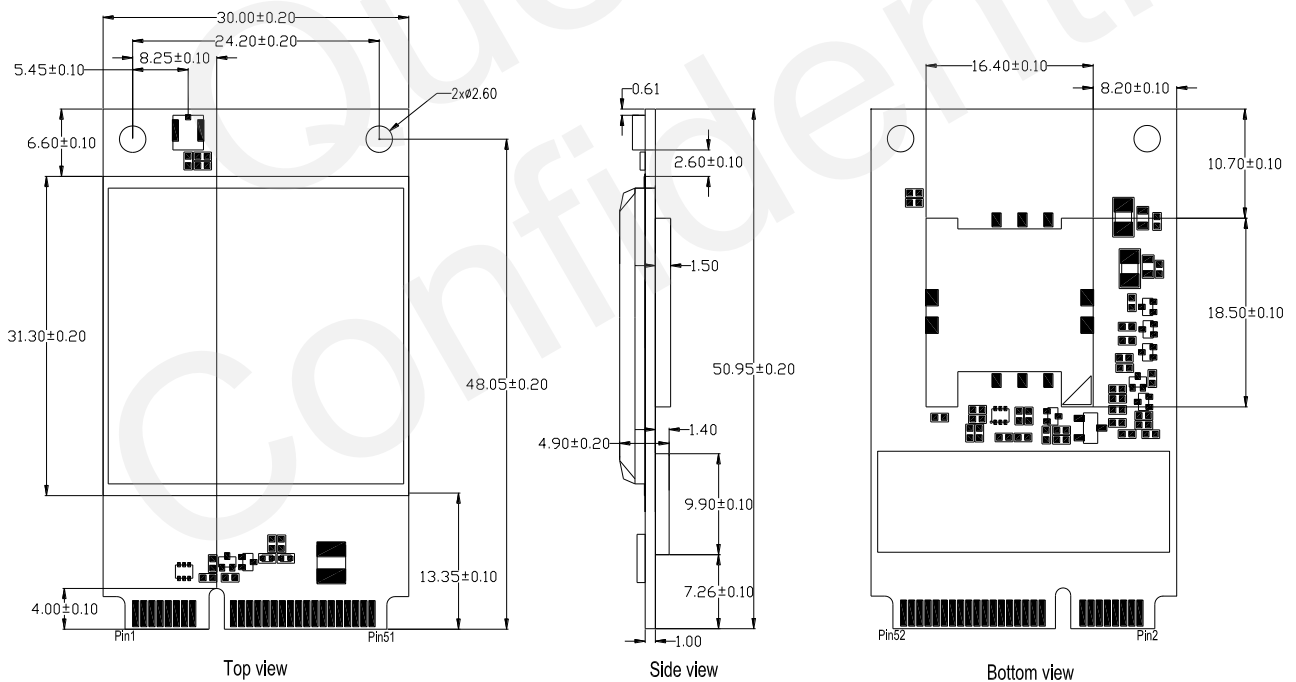

Figure 21: Mechanical Dimensions of UC15 Mini PCIe (Unit: mm)

5.3. Standard Dimensions of Mini PCI Express

The following figure shows the standard Dimensions of Mini PCI Express. Please refer to **document [1]** for detail A and detail B.

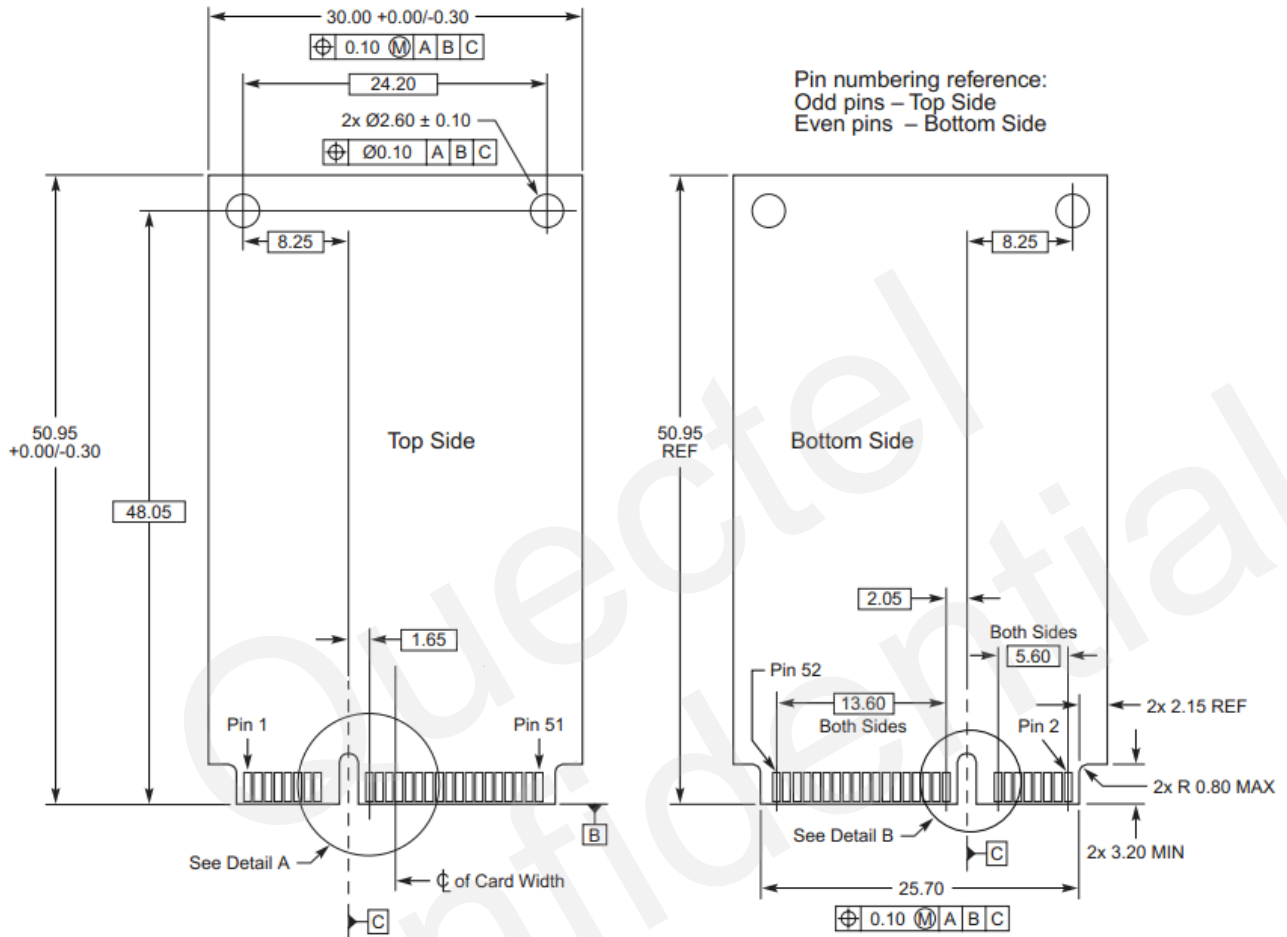

Figure 22: Standard Dimensions of Mini PCI Express (Unit: mm)

UC15 Mini PCIe adopts a standard Mini PCI Express connector which compiles with the standards listed in the **document [1]**. The following figure takes the Molex 679100002 as an example.

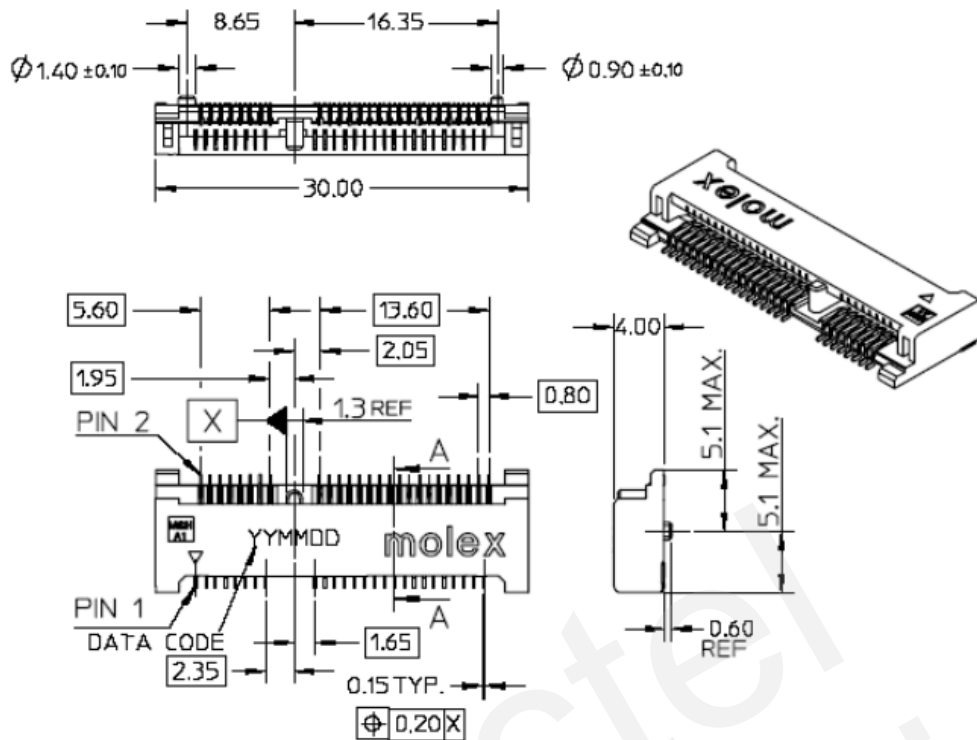

Figure 23: Dimensions of the Mini PCIe Express Connector (Unit: mm)

5.4. Packaging

The UC15 Mini PCIe is packaged in tray. Each tray contains 10pcs of modules. The smallest package of UC15 Mini PCIe contains 100pcs.

6 Appendix Reference

Table 24: Related Documents

SN	Document Name	Remark
[1]	PCI Express Mini Card Electromechanical Specification Revision 1.2	Mini PCI Express Specification.
[2]	Quectel_UC15_AT_Commands_Manual	UC15 AT Commands Manual.

Table 25: Terms and Abbreviations

Abbreviation	Description
bps	Bits Per Second
CS	Coding Scheme
CSD	Circuit Switched Data
CTS	Clear to Send
DCE	Data Communications Equipment (typically module)
DL	Down Link
DTE	Data Terminal Equipment (typically computer, external controller)
DTR	Data Terminal Ready
EMC	Electromagnetic Compatibility
ESD	Electrostatic Discharge
GMSK	Gaussian Minimum Shift Keying
GSM	Global System for Mobile Communications
HSDPA	High Speed Downlink Packet Access

I/O	Input/Output
kbps	Kilo Bits Per Second
LED	Light Emitting Diode
Mbps	Million Bits Per Second
MMS	Multimedia Messaging Service
MO	Mobile Originated
MT	Mobile Terminated
PAP	Password Authentication Protocol
PCM	Pulse Code Modulation
PDU	Protocol Data Unit
PPP	Point-to-Point Protocol
RF	Radio Frequency
RX	Receive Direction
SIM	Subscriber Identification Module
SMS	Short Message Service
TDMA	Time Division Multiple Access
TE	Terminal Equipment
TX	Transmitting Direction
UART	Universal Asynchronous Receiver & Transmitter
UL	Up Link
UMTS	Universal Mobile Telecommunications System
URC	Unsolicited Result Code
USSD	Unstructured Supplementary Service Data
WCDMA	Wideband Code Division Multiple Access